



TEMPERATURE CONTROLLED SOLDERING STATION  
OWNER'S OPERATION MANUAL

**RX-701 (AS) / RX-701L (AS)**  
**RX-711 (AS) / RX-711L (AS)**

AS series is the Anti-Static series

[www.procontechology.com.au](http://www.procontechology.com.au) Phone: (03) 98306288



## WARNING

Before using the soldering station, read the Owner's Operation Manual.

Failure to follow the safety precautions and instructions in this manual could result in serious injury and property damage.

Your new soldering station has been engineered and manufactured to the **goot** high standard for dependability, ease of operation and operator safety. If you follow the instructions and safety precautions in this manual and on the product and use the soldering station properly and only for what it is intended, you will then enjoy years of safe, reliable service. Thank you for buying the **goot** Soldering station.

**KEEP THIS MANUAL IN A SAFE PLACE FOR FUTURE REFERENCE.**

# 1

## TABLE OF CONTENTS /SPECIFICATIONS

|  |           |
|--|-----------|
| <b>1. TABLE OF CONTENTS / SPECIFICATIONS</b> ..... | <b>1</b>  |
| <b>2. INTRODUCTION</b> .....                       | <b>2</b>  |
| 2-1 UNPACKING .....                                | 2         |
| 2-2 NAME OF PARTS .....                            | 3         |
| 2-3 SAFETY .....                                   | 4         |
| <b>3. RULES FOR SAFE OPERATION</b> .....           | <b>5</b>  |
| <b>4. OPERATION</b> .....                          | <b>7</b>  |
| <b>5. MAINTENANCE</b> .....                        | <b>10</b> |
| 5-1 REPLACING THE TIP .....                        | 10        |
| 5-2 REPLACING THE HEATER .....                     | 10        |
| 5-3 TEMPERATURE CALIBRATION .....                  | 11        |
| 5-4 HOUSING CLEANING .....                         | 12        |
| <b>6. TROUBLESHOOTING GUIDE</b> .....              | <b>13</b> |
| <b>7. REPLACEMENT PARTS / OPTION</b> .....         | <b>14</b> |
| <b>8. PARTS LIST</b> .....                         | <b>15</b> |

### SPECIFICATIONS

| MODEL                                   |                | RX 701 701L 701AS 701LAS          | RX 711 711L 711AS 711LAS |
|---|----------------|-----------------------------------|--------------------------|
| Voltage                                 |                | 220, 230, 240VAC                  |                          |
| Power Consumption                       |                | 65W                               |                          |
| Output Voltage                          |                | 24V                               |                          |
| Temperature Setting Range               |                | 200—450°C                         | 200—480°C                |
| Insulation Resistance                   |                | Over 100MΩ / 500VDC               |                          |
| Size                                    | Control Unit   | 146(L) 115(W) 98(H) mm            |                          |
|   | Soldering Unit | 195 mm (w/o cord)                 |                          |
| Weight                                  | Control Unit   | 1.5kg (w/o cord)                  |                          |
|   | Soldering Unit | 41g (w/o cord)                    |                          |
| Soldering Unit Control Unit Cord Length |                | 1.2m                              |                          |
| AC Power Cord Length                    |                | 1.3m (3 core cable / ground plug) |                          |
| Leak Voltage                            |                | Under 2mV                         |                          |
| Ground Resistance                       |                | Under 2Ω                          |                          |

## 2 INTRODUCTION

### 2-1 UNPACKING

- Do not discard the packing material until you have carefully inspected and satisfactorily operated the soldering station.

### PACKING LIST

- Control Unit
- Soldering Unit
- Soldering Iron Stand
- Owner's Operation Manual

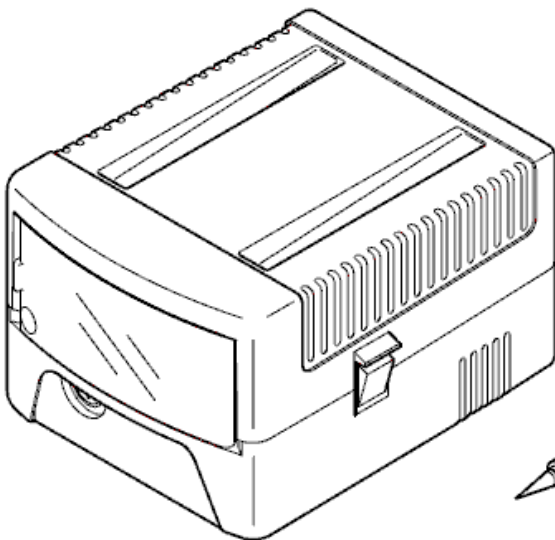

Control Unit

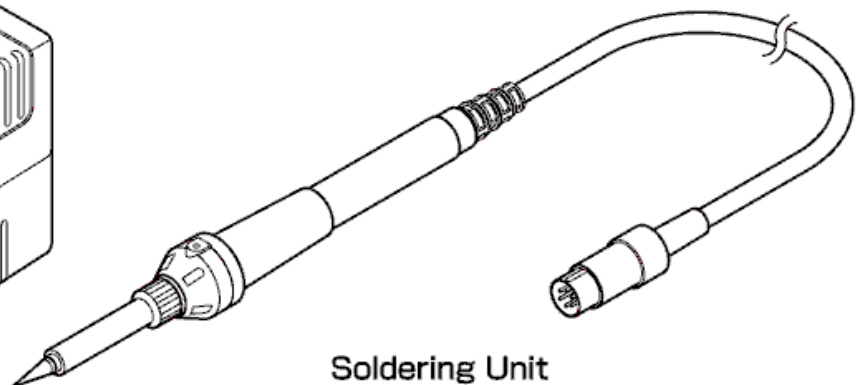

Soldering Unit

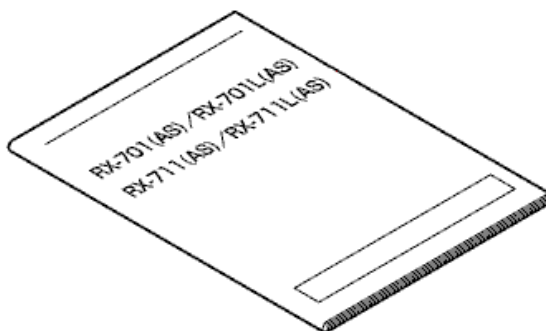

Owner's Operation Manual

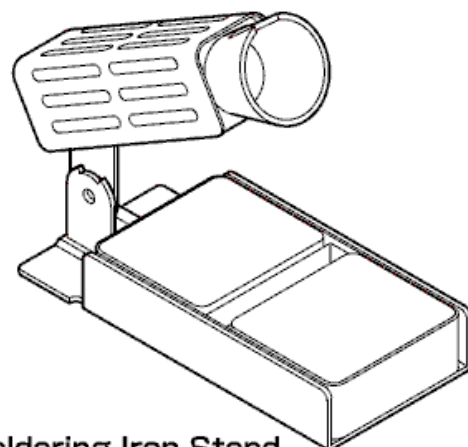

Soldering Iron Stand

2-2 NAME OF PARTS

LABELS (EXAMPLE)

Control Unit

Name Label (EXAMPLE)

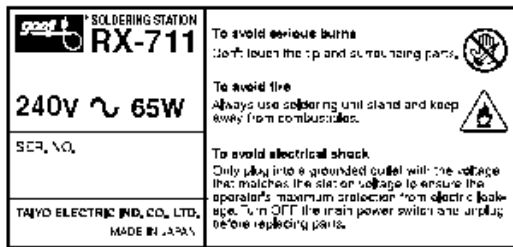

AS Label (AS model only)



Soldering Unit

Name Label (EXAMPLE)



AS Label (AS model only)

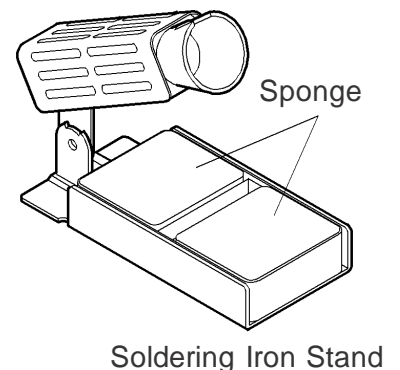
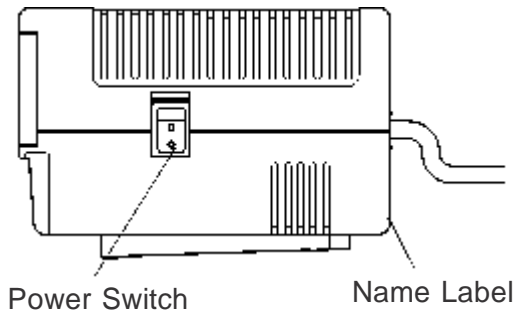
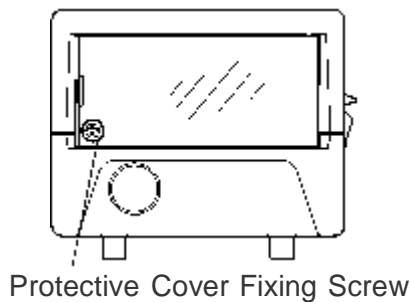
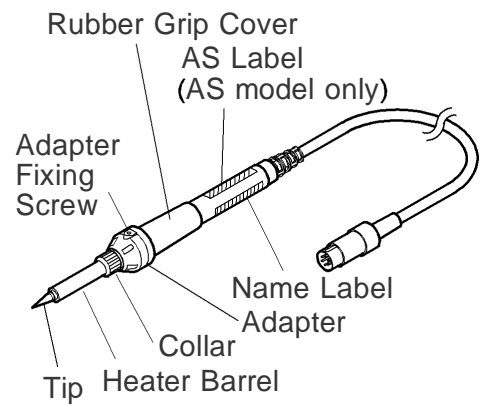
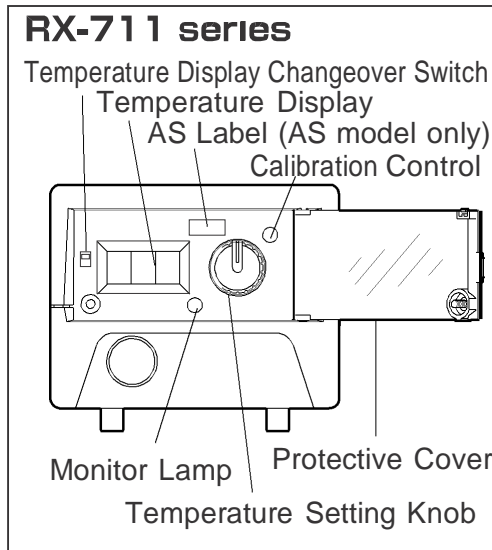
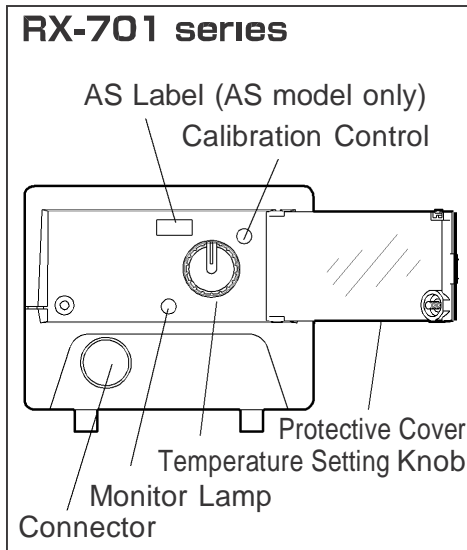

## 2-3 SAFETY



### **WARNING**

Failure to obey a safety warning could result in serious injury or death. Always follow the safety precautions given to reduce the risk of electric shock, fire or personal injury.



### **CAUTION**

Failure to obey a safety caution may result in a minor or moderate injury to yourself or to others. Always follow the safety precautions to reduce the risk of electric shock, fire or personal injury.

### **NOTE**

These messages advise you of information or instructions vital to the operation and maintenance of the soldering station.

## 3 RULES FOR SAFE OPERATION

### READ ALL INSTRUCTIONS



### WARNING

Do not attempt to operate this soldering station until you have read thoroughly and understand completely all instructions, safety rules, etc. contained in this manual. Failure to comply may result in accidents involving fire or serious personal injury.

#### 1. BEFORE OPERATING, PLEASE FULLY UNDERSTAND THE SOLDERING STATION.

Please read the owner's operation manual carefully and completely. Learn its applications and limitations as well as specific potential hazards related to this soldering station.

#### 2. DO NOT USE IN DANGEROUS ENVIRONMENTS.

Do not use the soldering station in damp, humid or wet locations. Never expose it to rain including outside.

Never use it in an explosive atmosphere. The heat from the heater could ignite fumes. Be sure that the work area is properly lit.

#### 3. KEEP CHILDREN AND BYSTANDERS AWAY FROM THE SOLDERING STATION.

Do not let bystanders touch the soldering station. All bystanders, especially children, should be kept a safe distance from the work area.

#### 4. PROPERLY STORE THE SOLDERING STATION WHEN NOT IN USE.

When not in use, the soldering station should be stored in a dry location, out of the reach of children.

#### 5. USE IT FOR THE RIGHT JOB.

This soldering station is an electrical tool used to solder parts and melt solder. Do not use the soldering station for any purpose not intended ——— for example ——— the soldering station should never be used to warm water or other liquids.

#### 6. WEAR PROPER APPAREL AND SAFETY GLASSES.

Do not wear loose clothing such as a necktie. Tie up long hair. Clothing or hair can burn by contacting the tip or surrounding heated parts.

#### 7. CONNECT TO THE SPECIFIED POWER SUPPLY.

The power voltage for this soldering station is indicated at back of the control unit. Never plug the soldering station into any other voltage.

**8. DO NOT ABUSE THE POWER CORD AND INSPECT IT PERIODICALLY.**

Never carry your soldering station by the power cord or yank the power cord to disconnect it from the receptacle. Keep the power cord away from heat, oil and sharp edges.

**9. DO NOT USE AN UNSUITABLE STAND.**

Be sure to use the ST-77 soldering iron stand included with the soldering station. If this stand is not used, the plastic parts (adapter and/or grip) of the soldering unit may be damaged.

**10. BE CAREFUL WHEN TURNING THE TEMPERATURE SETTING KNOB AND THE TEMPERATURE CALIBRATION VARIABLE CONTROL**

Do not turn the temperature setting knob beyond the scale range or the variable control may be damaged.

When turning the temperature calibration control to set the temperature, turn it slowly and stop when it becomes hard to turn or the control may be damaged.

**11. CONCERNING THE TIP**

Never use the soldering unit with the tip removed or the heater will be damaged. After unplugging, cool the tip in natural air. Never use any other method to cool it down ——— for example ——— Water should never be poured or sprinkled on the tip to cool it down.

**12. If the power cable is damaged then the soldering iron should be returned to the distributor for replacement or repair.****13. The soldering iron is not intended for use by young children or infirm persons without supervision. Young children should be supervised to ensure that they do not play with the soldering iron.****CONCERNING THE AS SERIES (Model RX-701AS,701LAS,711AS,711LAS)**

These soldering stations are the anti-static models. Be sure to properly ground the soldering station using a grounded receptacle to prevent electrical shock and static damage. If it is not properly grounded, electrical shock may occur.

As the soldering station uses conductive material, please be careful not to touch any electrical power source or a serious injury may result.

## 4 OPERATION



### WARNING

To prevent fire, keep the soldering station away from flammable substances and materials in the work area. Failure to do so could result in a serious accident.

1. Place the soldering station control unit and the soldering iron stand on a level work area that is well ventilated.

2. Connect the soldering unit to the control unit.

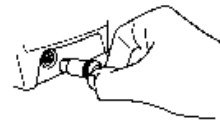

3. Place the soldering unit in the soldering iron stand. Adjust the soldering iron holder angle of the stand so that the soldering unit tip is facing down so it will not fall out.

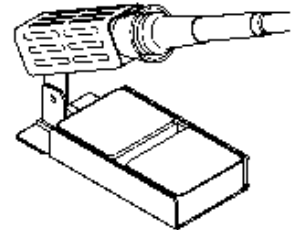

4. Check that the power switch on the control unit is OFF (the ○ mark side) and then plug the control unit in.

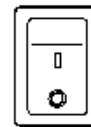

5. The power cord plug is a ground pin type. Plug it into a ground pin type receptacle to properly ground it. Never remove the ground pin.

6. Loosen the protective cover screw and open the protective cover.

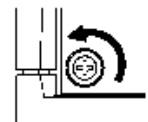

#### A. RX-701 series only

- A-1. Set the required temperature by using the temperature setting knob.

- A-2. Set the power switch to ON (the I mark side). The heater monitor lamp will light and the heater will start to heat up. When the heater temperature reaches the set temperature, the monitor lamp will flash. This indicates that the soldering unit is ready for use.

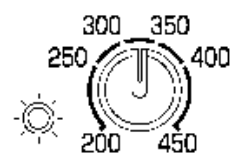
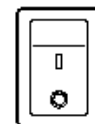

#### NOTE

When setting the temperature a short period of time is required before the temperature becomes stable.

After turning the power switch ON, the temperature will become stable after two minutes. Please wait two minutes before starting the soldering operation.



**B. RX-711 series only**

**B-1. Set the temperature display changeover switch on the left side of the front panel to the SET side. With the switch at this position, the temperature display shows the set temperature.**



**B-2. Set the power switch to ON (the I mark side).**

The heater monitor lamp will light and the heater will start to heat up. When turning the soldering station power switch ON from OFF, "999" will be initially displayed for approximately 10 seconds.

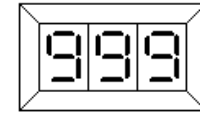
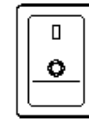

**B-3. Set the required temperature by using the temperature setting knob.**

**B-4. After doing the setting, when changing the switch to the MEAS side the digital display will show the measured temperature. When the heater temperature reaches the set temperature, the monitor lamp will flash. This indicates that the soldering unit is ready for use.**



When turning the soldering station power ON again after turning it OFF within one hour, the temperature displayed will lower to "000" and then will display measured temperature.

**CAUTION**

Do not turn the temperature setting knob beyond 480°C. By turning the temperature setting knob clockwise toward "MAX.", the required temperature and tip temperature can be set beyond 480°C. It may go up to approx. 510°C. Setting beyond 500°C could result in damage to your soldering station.

**NOTE 1**

There may be a difference of 2°C between the SET and MEAS temperature display. When the soldering station is shipped the temperature calibration is done with the temperature display set on the SET side. With the temperature display set on the MEAS side correction of the tip temperature by using the temperature setting knob is not required.

**NOTE 2**

When the temperature display is set on MEAS, the temperature displayed will fluctuate from 2 to 3 degrees Celsius.

**NOTE 3**

When the temperature display is set on MEAS if a heat load is placed for 10 seconds, the temperature display will not change.

**Example**—— While contacting the tip on a wet sponge, the actual tip temperature will drop for 10 seconds. However the temperature shown on the display will be the one before the tip was touched on the sponge.

The actual temperature will be shown on the display 10 seconds later. The temperature control circuit works to recover the set temperature when the tip is cooled immediately even though the display of measured temperature is not changed.

**NOTE  
4**

When setting the temperature a short period of time is required before the temperature becomes stable.

After turning the power switch ON, the temperature will become stable after two minutes. Please wait two minutes before starting the soldering operation.

**WARNING**

If a burnt smell, unusual heating or housing melting occurs unplug the soldering station. Do not attempt to use it. If used a fire or other accident may be caused resulting in serious injury or property damage. Return it to the dealer or store it was purchased from.

**WARNING**

The tip, heater barrel, collar and adapter generate high temperatures. Never touch these or serious burns will result.

7. Close the protective cover and secure it by tightening the screw on the lower left side using a Phillips-head (+) screwdriver.

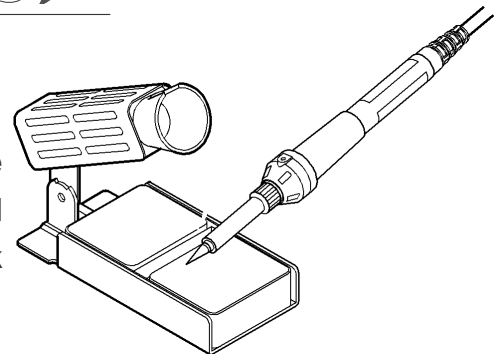

8. Remove any solder scraps on the tip, with the heat resistant sponge of the soldering stand moistened with water, during the soldering work periodically.

**CAUTION**

Do not drop the soldering unit or hit the soldering unit tip against a hard surface or the heater may be damaged.

**CAUTION**

If used at a temperature of 500°C or higher the soldering station will be damaged.

## 5 MAINTENANCE



### WARNING

When replacing the tip, heater barrel, collar, heater or other parts, be sure to unplug the soldering station and allow the soldering unit to fully cool down. Failure to follow this will result in possible electrical shocks, serious burns or a serious injury.



### CAUTION

When doing maintenance use only genuine *goot* replacement parts. The use of any other parts may create a hazard or cause damage to the soldering station.

#### 5-1. Replacing the tip

Procedure

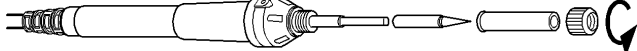
1. Remove the collar by turning it in the counter-clockwise direction. 
2. Pull off the heater barrel. Pull off the tip from the heater.
3. In order to reduce the tip and heater from sticking together, a tip casing is fitted in the tip. When removing the tip, the tip casing may stay on to the heater. The tip casing should be removed from the heater before mounting the new tip.
4. After mounting the new tip with casing on the heater, reassemble by reversing the disassembly procedure.

#### NOTE

To prevent the tip from sticking, periodically remove the tip from the heater and remove any oxidation that may have built up inside. Be careful that the insert does not fall out.

#### 5-2 Replacing the heater

Procedure

1. Slightly loosen the collar.
2. Loosen the adapter fixing screw using a screwdriver.
3. Turn the adapter counter-clockwise and pull it off over the tip. Remove the two connectors, one for the heater and the other for the ground and remove the heater

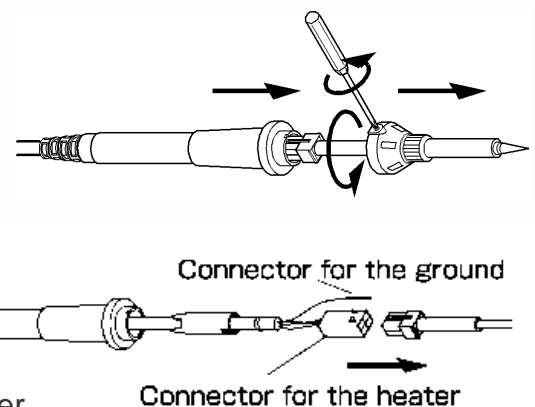

4. If the tip casing is on the heater, remove it and place it back in the tip. Then mount the new heater.
5. After mounting the new heater, reassemble by reversing the disassembly procedures.

### 5-3 Temperature calibration (A tip thermometer is required)

Procedure

#### A. RX-701 series only

1. Set the required temperature for calibration by using the temperature setting knob.
2. Measure the tip temperature by the tip thermometer after the set temperature becomes stable.
3. Adjust so that the measured temperature matches the set temperature by turning the calibration control (CAL.) slowly using a standard screwdriver whilst measuring the temperature.

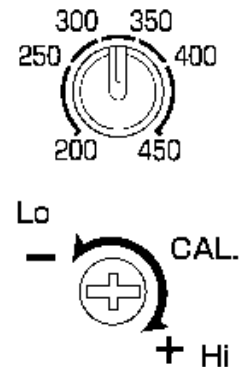

The tip temperature increases by turning the calibration control (CAL.) clockwise and decreases by turning it counter-clockwise.

**<Example>** Temperature calibration at 350°C.

1. Set the temperature to 350°C by using the temperature setting knob.
2. Measure the tip temperature by the tip thermometer after set temperature becomes stable.
3. If the tip thermometer displays 330°C for example, adjust the temperature of soldering tip to be 350°C by turning the calibration control (CAL.) slowly using a standard screwdriver whilst checking the temperature.

#### B. RX-711 series only

1. Set the temperature display changeover switch to the SET position.
2. Set the required temperature for calibration on the digital display by using the temperature setting knob.
3. Measure the tip temperature by the tip thermometer after the set temperature becomes stable.
4. Adjust so that the measured temperature matches the set (displayed) temperature by turning the calibration control (CAL.) slowly using a standard screwdriver whilst measuring.

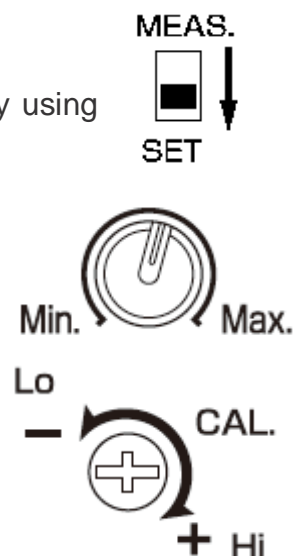

The tip temperature increases by turning the calibration control (CAL.) clockwise and decreases by turning it counter-clockwise.

**<Example>** Temperature calibration.

1. Set the temperature display changeover switch to the SET position.
2. Set the temperature at 350°C on the digital display by using the temperature setting knob.
3. Measure the tip temperature by the tip thermometer after the set temperature becomes stable.

4. If the tip thermometer displays 330°C for example, adjust the temperature of soldering tip to be 350°C by turning the calibration control (CAL.) slowly using a standard screwdriver whilst checking the temperature.

**NOTE  
1**

This soldering station is shipped with the temperature calibrated to 350°C. The tip temperature and the display temperature difference at 200°C and 450°C (RX-701 series) or 480°C (RX-711 series) is  $\pm 10^\circ\text{C}$ . There may be difference depending on the tip thermometer.

**NOTE  
2**

To prevent damage to the components on PCB and/or your soldering iron, be sure to do the temperature calibration after replacing the soldering unit or the heater. Please ask our authorized distributor if you are unable to do the temperature calibration and/or for any questions.

#### 5-4. CLEANING THE HOUSING

Do not at any time allow gasoline, petroleum-based products, penetrating oils, etc. to come in contact with the plastic parts. They contain chemicals that can damage, weaken, or destroy plastics.

## 6 TROUBLESHOOTING GUIDE

### PROCEED AS FOLLOWS WHEN TROUBLE OCCURS:

1. Check that there is voltage in the receptacle and that the circuit breaker is not tripped.
2. Check that the power cord is not damaged. If it is damaged, do not use your soldering station and return it to the **goot** distributor for service.
3. If 1 and 2 above are OK, follow the flow chart below to find the cause of the trouble to correct it quickly.

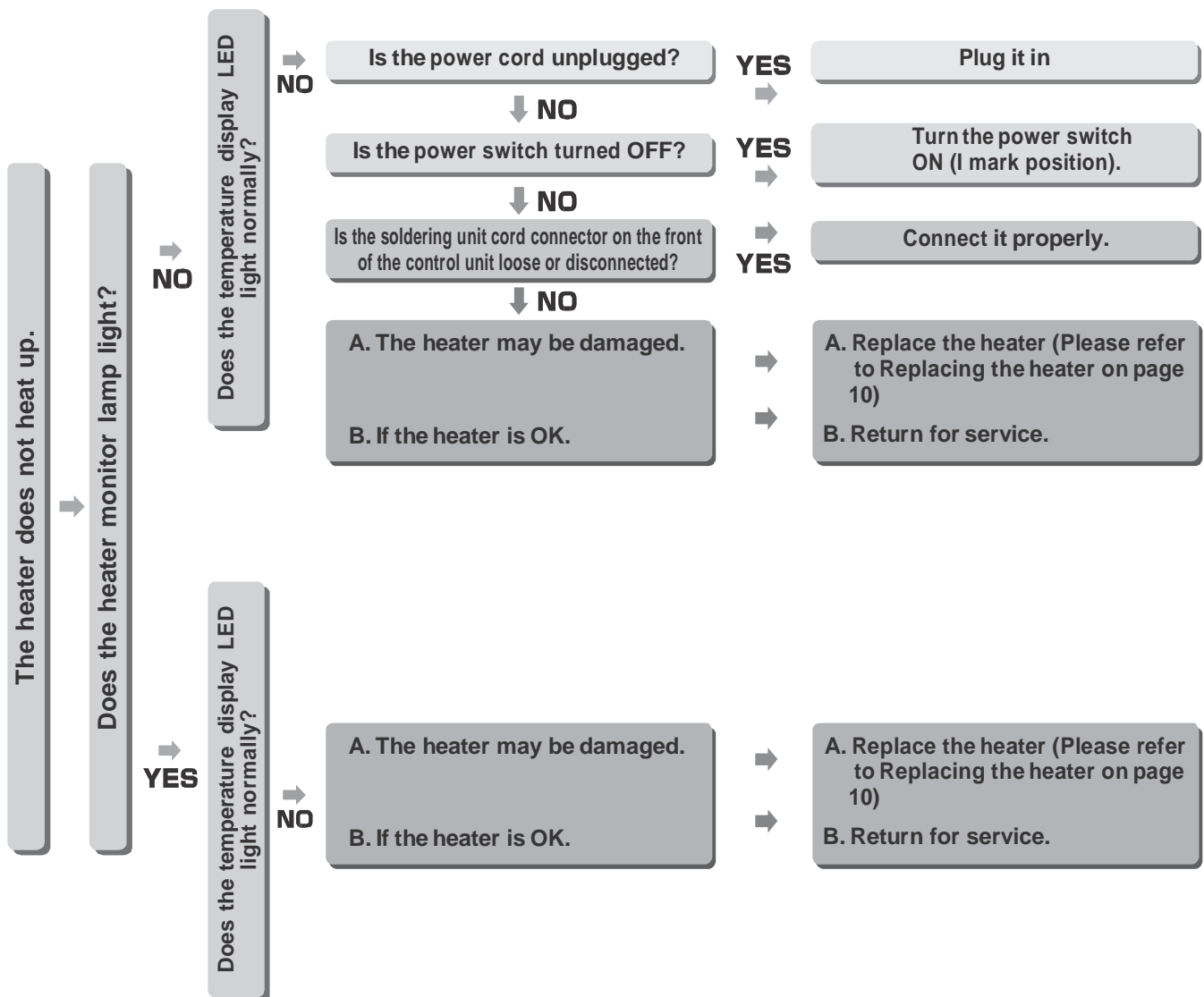

4. If any plastic part is deformed or a burnt smell is noticed, unplug your soldering iron immediately and return it to the **goot** distributor for service.
5. If your control unit or soldering unit was dropped, check the above carefully. If there is a problem, do not use it and return it to the **goot** distributor for service.

# 7 REPLACEMENT PARTS

## M type soldering unit (Normal)

For soldering precision components.

## L type soldering unit (Large)

For soldering large components or when the set temperature is low.

### Replacement Tips for M Type Soldering Unit

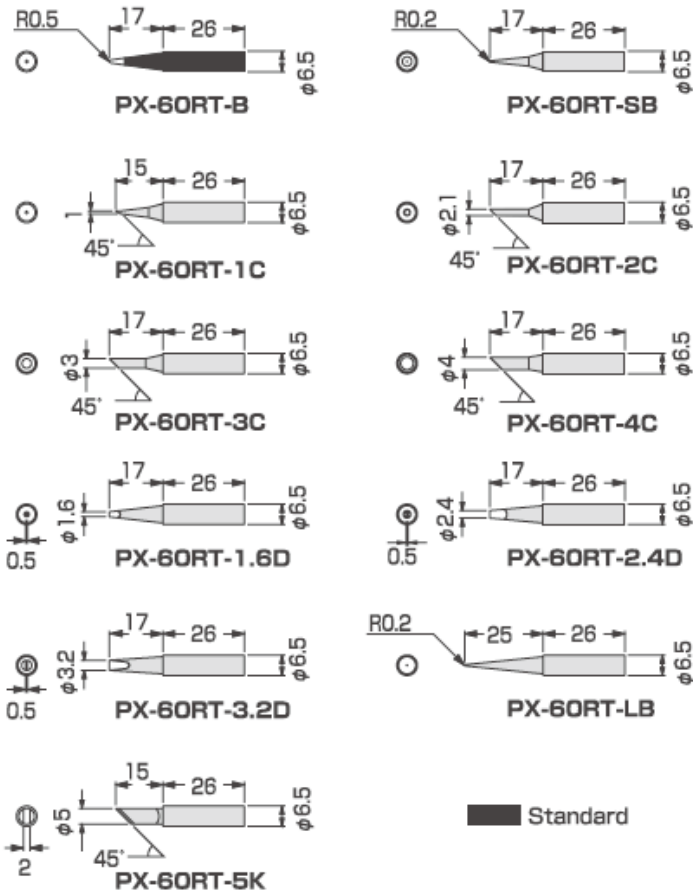

### Replacement Tips for L Type Soldering Unit

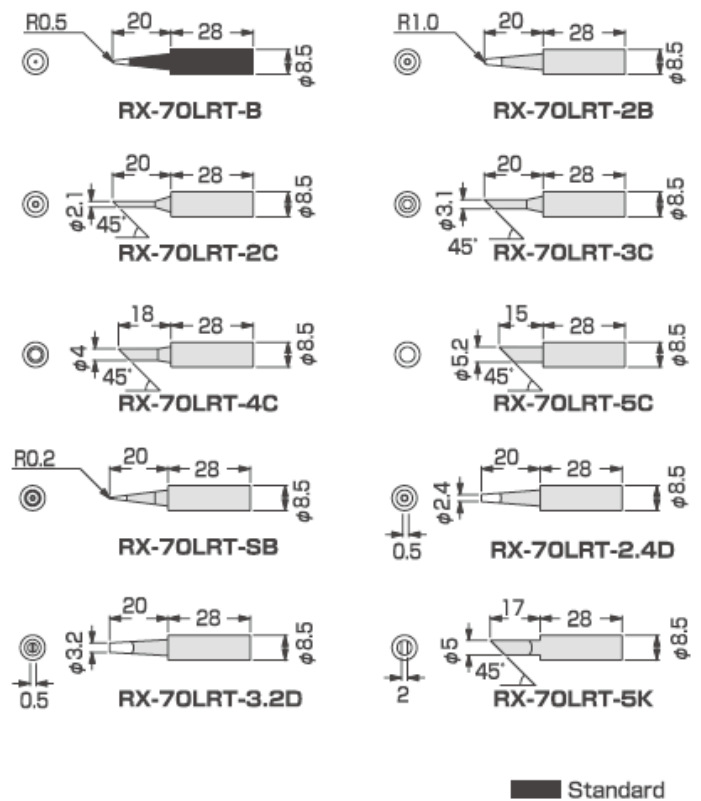

### Round solder-plated tip

For C type tip of the PX-60RT and RX-70LRT series.

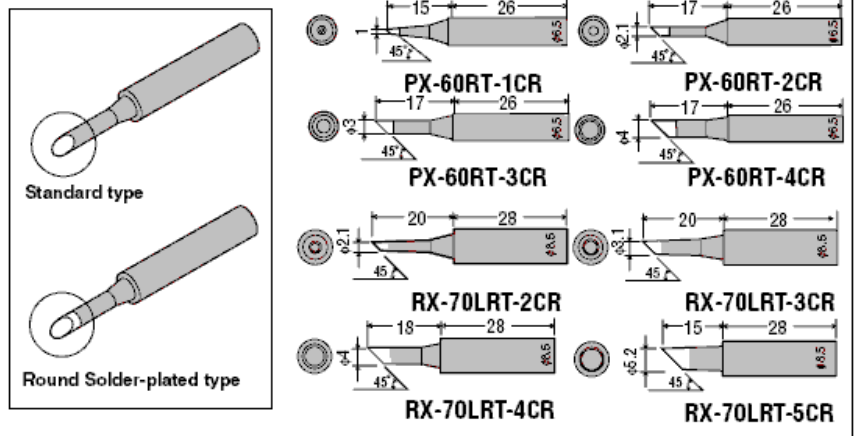

## 8 PARTS LIST

For the replacement parts, see page 14. Contact the *goat* distributor to order spare parts.

| No. | Parts Name           | Code      | Note                       |                     |
|-----|----------------------|-----------|----------------------------|---------------------|
| 1   | Protective cover     | A0810DX00 |                            |                     |
| 2   | Soldering unit       | A0853AG00 | RX-70G                     | M size tips only    |
|     |                      | A0853EG00 | RX 70GAS                   |                     |
|     |                      | A0853JG00 | RX 70LG                    | L size tips only    |
|     |                      | A0853LG00 | RX 70LGAS                  |                     |
| 3   | Rubber grip cover    | T0005CM00 |                            |                     |
|     |                      | T0006CM00 | AS model only              |                     |
| 4   | Heater               | B0852AH00 | RX 70H                     |                     |
| 5   | Adapter              | A0670DL00 | RX-70G use                 | M size tips only    |
|     |                      | A0680DL00 | RX-70GAS use               |                     |
|     |                      | A0850KT00 | RX-70LG use                | L size tips only    |
|     |                      | A0850MT00 | RX-70LGAS use              |                     |
| 6   | Adapter fixing screw | T0207ST10 | M2.6 7                     |                     |
| 7   | Tip                  | B0672AB00 | PX 60RT B                  | Standard M size tip |
|     |                      | B0852AB00 | RX 70LRT B                 | Standard L size tip |
| 8   | Heater barrel        | T0039MS00 | PX 60HP M size tips only   |                     |
|     |                      | T0046MS00 | RX 70LHP L size tips only  |                     |
| 9   | Collar               | T0001CS00 | TQ 77NUT M size tips only  |                     |
|     |                      | T0012CS00 | RX 70LNUT L size tips only |                     |
| 10  | Sponge               | B6782SP00 | ST 70/75SP                 |                     |



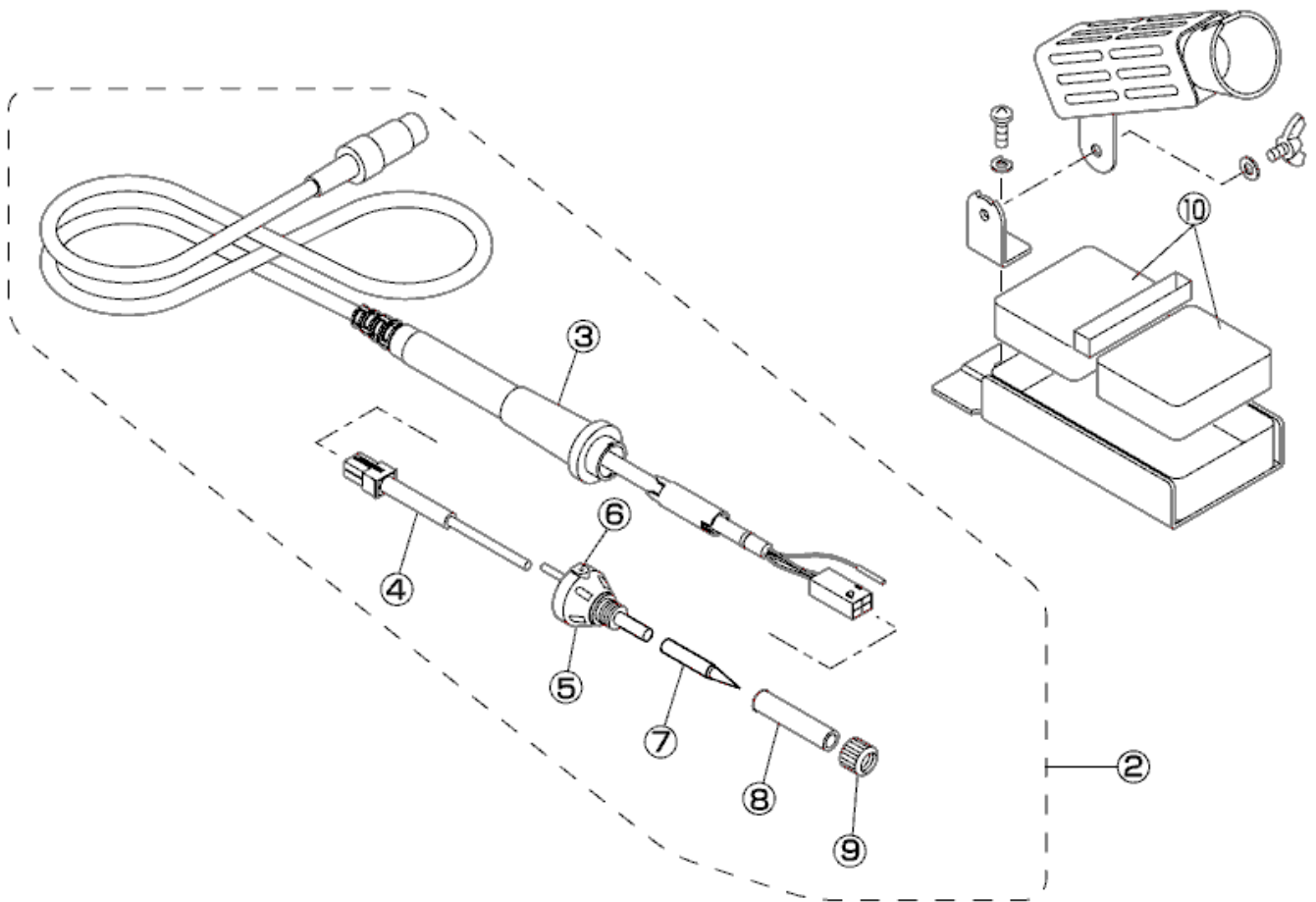

For service or replacement parts, heater elements, tips etc. Contact your nearest distributor or the following:

## TAIYO ELECTRIC IND.CO. LTD.

Tel : +81-84-9511512

Fax : +81-84-9519531

e-mail : [info@goot.co.jp](mailto:info@goot.co.jp)

Website: [www.goot.co.jp](http://www.goot.co.jp)