

THE VK5BR X2-X3 SMALL DIPOLE ANTENNAS



**X3 80 metre
Antenna
(2 Metres High)**

[A small loaded dipole fed via balanced open line so that tuning and and matching for frequency change can be controlled from within the radio shack.]

by Lloyd Butler VK5BR

[Updated March 4, 2005]

Forward

The VK5BR_X antenna is a small loaded dipole which makes use of resonant balanced lines to allow adjustment of matching and frequency tuning from within the radio shack. The original construction was aimed at setting magnetic fields from the series coils so that they crossed the electric fields from the dipole in phase to enhance radiation in accordance with the controversial crossed field theory. Earlier tests showing considerable antenna resistance above that of loading coil resistance pointed to improved radiation from the crossed fields. However it was eventually discovered that there were other reasons for the increased resistance and hence such enhancement has not been proven.

By using open wire balanced line, no fine pre-tuning is required at the antenna and tracking of tuning is achieved back in the radio shack using a Z Match tuner or other similar matching unit with balanced output.

There are two versions of this antenna. The X2 coils are series fed straight from the open wire. The X3 is shunt fed by coupling the line to taps on the coils. A minor wiring change can convert from one form to the other on the same antenna assembly. Assembly details are shown for antennas on the 10, 20, 40 and 80 metre bands. .

Theory

The original idea of crossed fields in this antenna is demonstrated in figure 1. To understand the anticipated operation, you have to think somewhat in reverse and assume that the antenna is working in the crossed field to start with. The impedance then seen looking into the antenna is dominantly resistance resulting from radiation.

Because the impedance is essentially resistive, the current flowing into the antenna is essentially in phase with the voltage across the antenna from which the E field is developed. To maintain an H field in phase with that voltage (and the E field), you simply set up the H field from current flowing into the antenna by means of open series coils. The two coils have been placed so that the dominant spread of their magnetic fields is at right angles the electric (E) field between the cylinders.

The coils are wound to provide a total series inductive reactance to balance the capacitive reactance of the antenna. The precise inductance to achieve this is not critical as resonance is easily tracked using by the remote matching and tuning reflected via the open wire line.

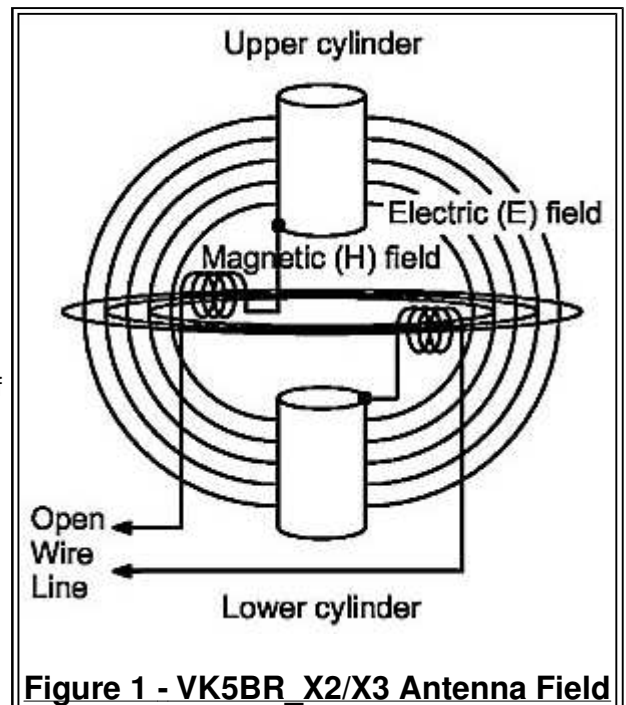
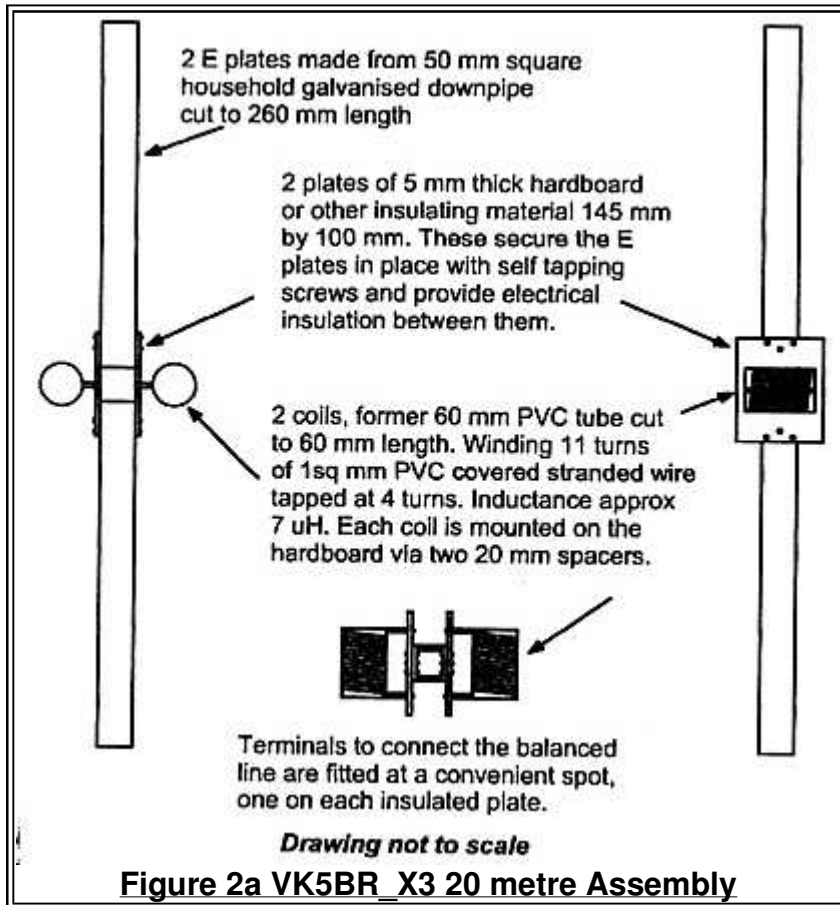

Figure 1 - VK5BR_X2/X3 Antenna Field

Figures 2a and 2b show the assembly of the 20 metre X3 antenna. The X2 antenna is similar except that there are no taps on the coils. The two coils are placed so that their magnetic fields are in the path of the dipole E fields and the

magnetic fields are assumed to be essentially at right angles to the E field as shown in figure 1. The current through the coils is the current fed to the cylinders. Two coils are used so that the circuit is balanced and there is no problem of longitudinal current flow.

By using open wire balanced line, the lines can be operated in a partly tuned mode enabling matching of the antenna to be adjusted within the radio shack by a balanced output tuner such as the Z Match. Open wire lines have very low loss at HF frequencies, even in a tuned mode. To learn more about this, read my article ["The Merits of Open Wire Lines"](#). (Reference 1). The arrangement for Version X2 is shown in figure 3.



The complete tuning systems for the X2 and X3 antennas are shown in figures 3 and 4.

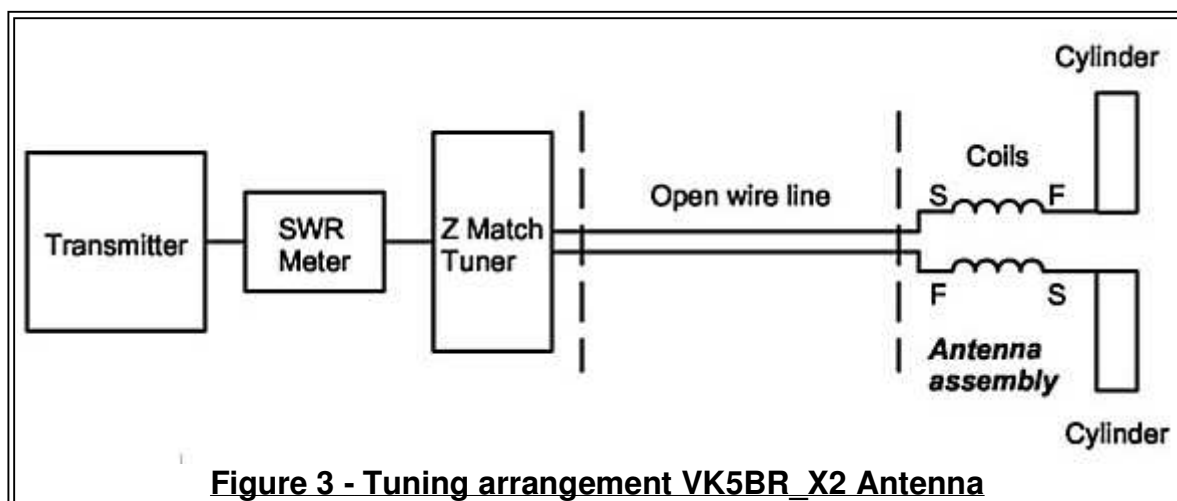

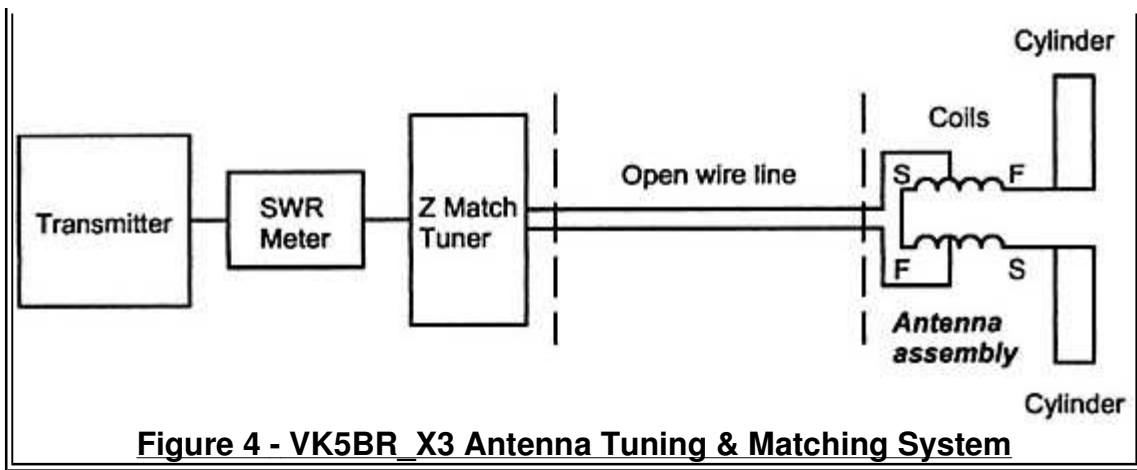

For my tests, I used the old open wire TV line, but it is very hard to get hold of these days. Using about 12 metres of this line in conjunction with a Z Match tuner at 14 MHz, I measured about 1 dB loss in the transmission system.

Ordinary figure of 8 twin power flex or 300 ohm TV ribbon can be used at the lower HF frequencies if the line is not too long. However at the higher frequencies (say 14 MHz), more than half the power could easily be lost in the cable.

In Version X3 Antenna, instead of series feeding the coils, their series ends have been joined together and they are connected to the open wire line via taps on the coil. (See Figures 4 & 5). So instead of the resonant line looking at its end to a low terminal series resistance, the coupling system increases the value of the terminal resistive component. The idea is to reduce the standing wave loss on the tuned line and hopefully also reduce losses in the Z Match tuner which might have less extreme values of impedance reflected. However which of the connections (X2 or X3) are the most efficient can depend on the actual length of the line. Also if impedance reflected back to the Z match tuner appears out of its range for one connection, it may be OK for the other connection. I have also had the experience where I have had arcing problems across the tuner capacitors which have been stopped by changing to the other connection.

More detail of the coil connections is shown in figure 5

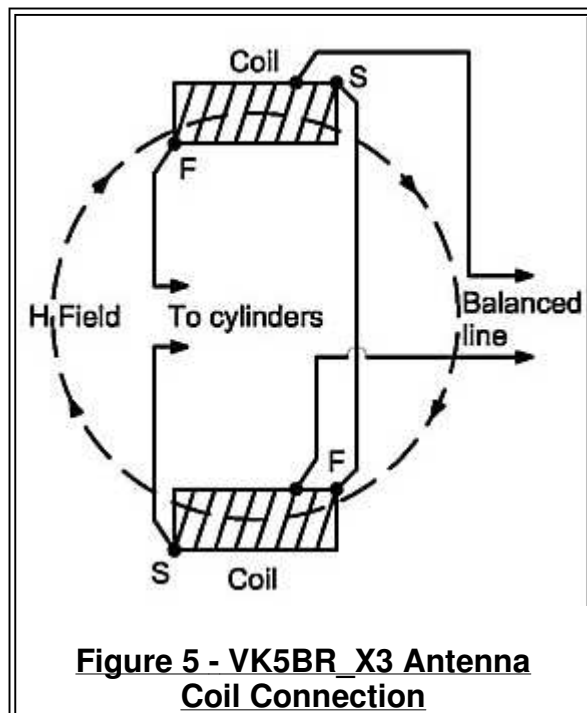

The ideal situation is for the the antenna coils to be resonant with the antenna capacitance at the centre of the band and the tap set so that a resistance is reflected at the tap equal to the characteristic impedance of the line (say 300 ohms). The Z Match tuner at the transmitter end is used to transform the 300 ohm line load to 50 ohms at the transmitter (indicated by SWR of 1:1 at that end). As the frequency is changed from that at resonance, the terminal impedance changes to that of a complex value. The mismatch is corrected by reflecting conjugate reactance up the line from the Z Match which is re-adjusted for an SWR reading of 1:1 facing the transmitter.

So an ideal situation is for a matched open wire line at the centre of the band changing to partial resonant feeders as you

tune either side of the band centre. However in practice its not all that critical and all one needs to do is set the coils for somewhere near resonance and let the tuner adjustment do the rest by reflecting conjugate impedance down the line.

Although the combined inductance of the coils does not have to be that critical, I set resonance of them with antenna capacitance somewhere within the centre of the band. I do this by putting more turns on the coils than I think I need and trimming back until a suitable resonant frequency is indicated by a Dip Meter placed close to the end of one of the coils.

Because the junction between the two coils in the X3 antenna is an electrical centre, the antenna can be operated with an earth at this point with little difference in performance. This makes it easier to monitor voltages using the CRO to compare the phase of voltage at the cylinders to the phase of the H field developed by the coils. It also makes it possible to earth the antenna to a supporting metal structure if required. However if there is a small unbalance in the system, a small current flows in the earth connection wire and this results in a small proportion of power being radiated from the earth connection lead. To inhibit this current, a choke or parallel resonant trap can be inserted in the earth lead.

In fixing the antenna in place as a radiator, the balanced feeder cable should connect to the centre of the antenna with the cable at right angles to the line of the antenna and continue for some distance in the right angled line so that it has minimal interference with the field from the dipole cylinders. The same applies to an earth lead if used. The earth lead should also be spaced a little distance from the line so that it does not upset the line balance.

Also in mounting the antenna, it should be kept away from metal objects as much as possible to prevent interference to the antenna fields.

Earlier tests using a field strength meter at close range indicated that the X2 and X3 antennas tuned for 20 metres exhibited a slightly bi-directional characteristic when the antennas were mounted in the horizontal plane. Also the signal was a little stronger in the vertical plane with its maximum when the antenna was tilted forward a little. It was later discovered that this was apparently a characteristic of the induction or near field and at distance, the radiated signal was actually strongest with the antenna mounted in the vertical plane.

Assembly Details

The dipoles of the antennas are square rather than round. This was done to simplify the assembly holding the E plates apart and mounting the H field generating coils. For the 20, 40 and 80 metre versions, I used 50mm square galvanised pipe. For 10 metres, I used 25mm square aluminium pipe. As can be seen from the diagrams, there are two simple rectangular plates made from some form of insulating material. I initially used some tempered hardboard as shown in the diagrams but this proved to be lossy and polystyrene or polythene is much better,

Assembly details for the 40 and 80 metre antenna are shown in figures 6 and 7.

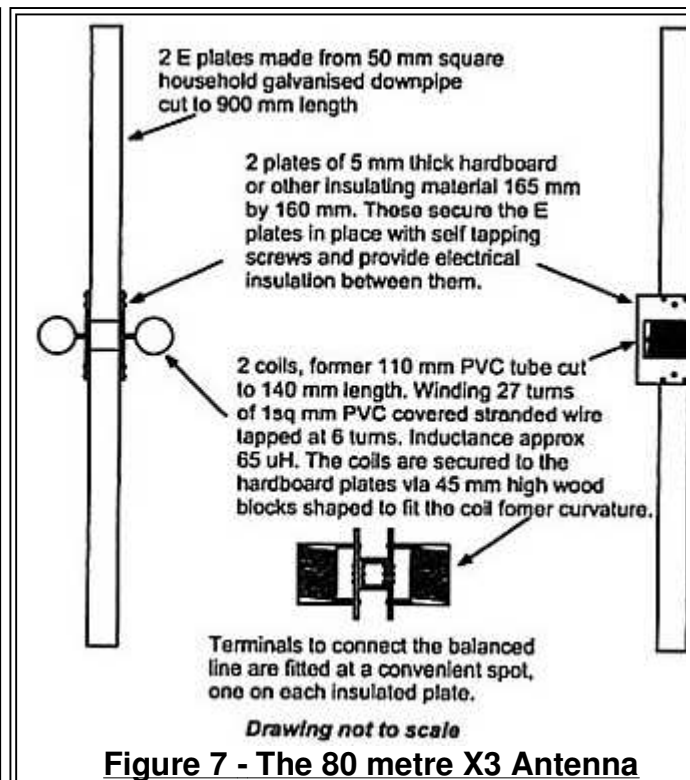
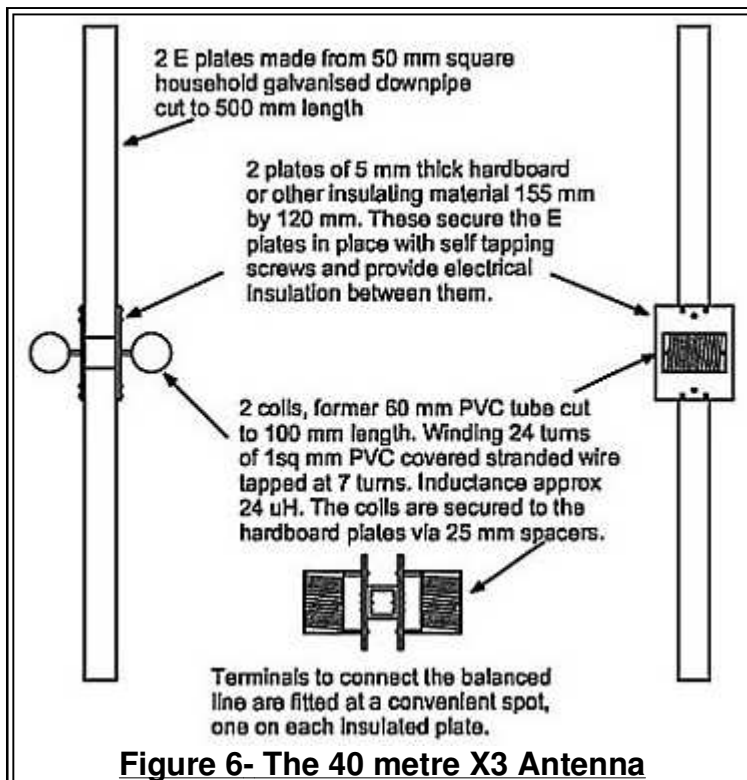

Some more photos:



X3 40 Metre Antenna

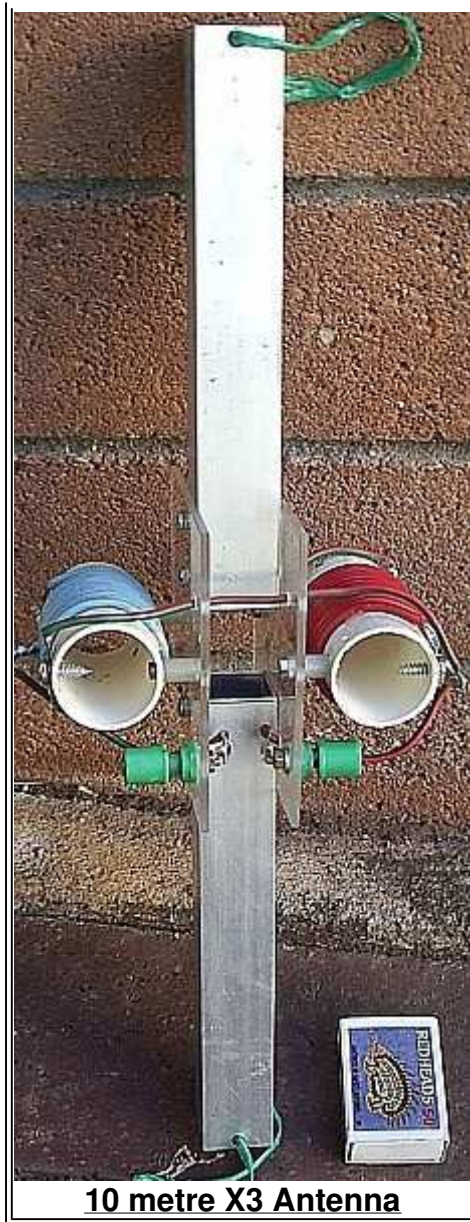

10 metre X3 Antenna



X3 40 Metre Antenna Coil Assembly



The 80 metre Coil Assembly

The 10 metre antenna was assembled essentially as a small enough wavelength to allow far field measurements in my suburban back yard. No assembly drawing is shown but the antenna is constructed on similar assembly lines to the lower frequency versions shown in figures 7, 8 & 11.

The dipole legs are made of 25mm (1 inch) square aluminium tube and each leg is 170mm long. The legs are separated by a gap of 30mm.

The two coils are each 11 turns of 1sq.mm PVC covered stranded wire, tapped at 3 turns and wound on 34mm PVC round tube which is cut to 65mm length. They each have an inductance of 3 uH. The two coils in series resonate with the dipole capacitance within the 28 MHz band.

Two Plexiglas plates 95mm x 85mm are screwed to the square dipole plates to secure them apart and provide a mount for the two coils similar to the assembly in the lower frequency antennas. The coils are bolted through 10 mm spacers to the plates.

E-H phase Testing

The initial purpose of the X2/X3 was to check out how it might perform as a crossed field antenna. As such it was necessary to compare the phase relationship between H field generated by current through the coils and the E field generated across the dipole plates. This was carried out using a dual trace CRO. The operation is a bit tricky as the CRO leads pick up stray longitudinal voltage which can give false indication of what is being read.

Figure 8 shows the arrangement I used to carry out these tests on the 40 metre X2 and X3. As shown on the diagram. I cast aside the usual the high impedance probes and used direct connection to the CRO inputs across a very low terminal resistance which discourages stray signal pick-up.

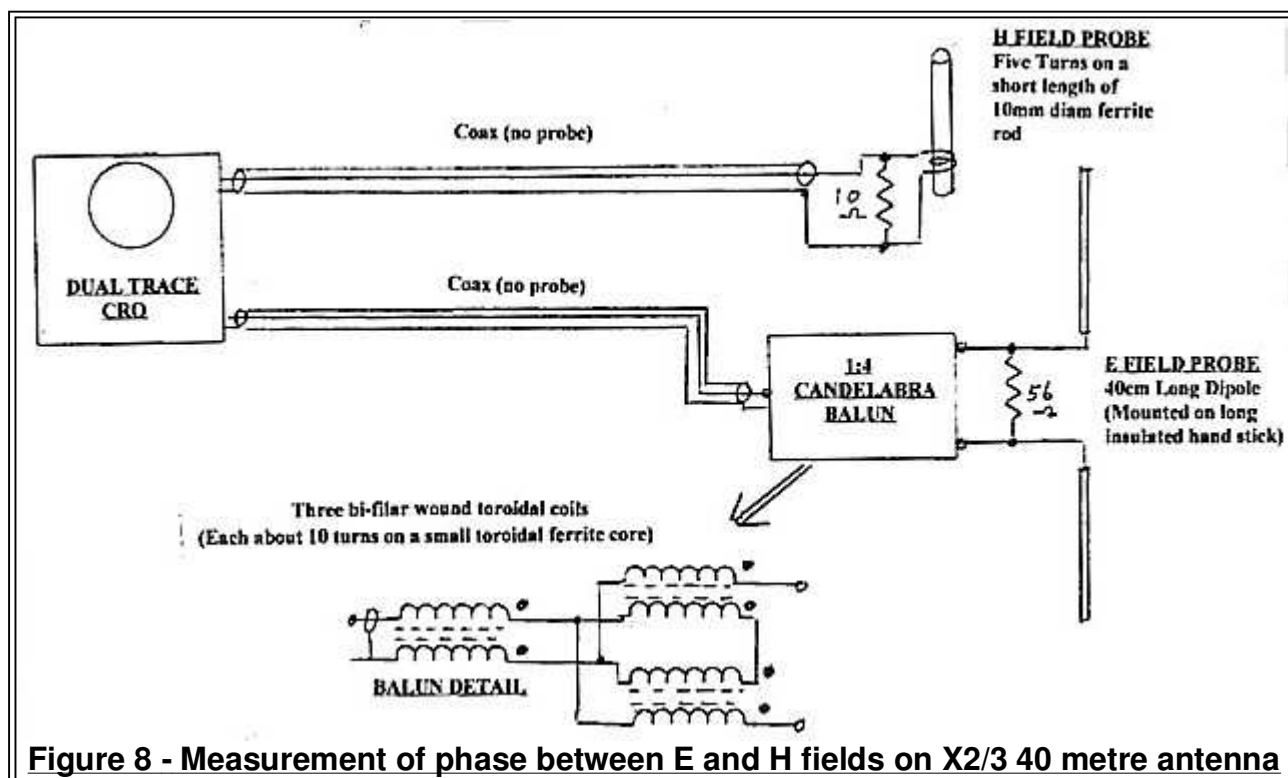

The H probe, which I poke near the end of either of the coils, is a few turns around a ferrite rod and terminated in a very low resistance (10 ohms) so that the voltage fed to the CRO is a picture of the current induced from the magnetic field.

The E probe is a short dipole which is terminated in as low a resistance as possible but sufficient to get a reading on the CRO when the antenna is fed from the highest level from my sig-gen. By using this and isolating with my candelabrum balun, I can get sufficient pick-up of the 40 metre X2/3 antenna electric field by holding the dipole a few inches away from the centre of the antenna without the longitudinal interference.

The result of the tests have shown that my original theory was on target and that the current through the coils (and hence the H field) is in phase with the E field when the circuit is operating around resonance. The test was carried out for both the X2 and X3 connections. The tests were confirmed by using both a signal generator fed direct to the antenna input and using the transmitter output fed via the Z Match and a short length of open wire balanced line.

There is one observation which is interesting. When the E field probe is moved away from the centre, the phase shifts toward 90 degrees difference and appears to be indicating the E field from a dipole end to reference ground. Each end is in anti-phase to the opposite end, which it should be, indicating that the field to ground is balanced out by the balanced form of the antenna.

Right from the first tests of the X2 or X3, it was clear that the fields from these antennas were different to the EH antennas. If you hold a fluoro lamp with the hand in front of an EH antenna and run it up and down, the fluoro lights continuously with maximum brilliance when you are adjacent to the antenna centre. But if you do the same for an X

antenna, the fluoro lights up best towards either of the two antenna ends and goes through a null when adjacent to the antenna centre.

However, if you mount the fluoro on an insulating stick so that you keep your body well away from the fluoro, you get a continuous light passing adjacent to the centre of the X antenna as for the EH.

It appears that holding the lamp with the hand provides an earth reference for the fluoro and it is lit from the field between the antenna and the earth reference. Near the centre of the antenna, these fields are equal and in anti-phase and the fluoro extinguishes. Get rid of the hand proximity, the fluoro is not subjected to the earth reference and it is lit essentially by the field between the dipole elements.

Some Field Tests

In general, tests on the X2/X3 antennas have been carried out with them mounted in the vertical plane around 2 metres above the ground

The field strength of the 20 metre X3 antenna was compared with that from the 20 metre L+L EH antenna which has a similar sized dipole to that of 20 metre X2/X3. The field strength at 5 metres from the X2/X3 antenna was found to be similar to that of the L+L antenna when a trap is fitted at the base of the L+L antenna to inhibit longitudinal radiation..

However with the trap was fitted at 1.5 metres down from the L+L antenna input connector, the L+L was about 3 or 4 dB better. A similar result was achieved with the trap fitted at 1.5 metres on the Star EH antenna.

With the trap fitted down its cable, the EH antenna has a tail, The improvement in the performance of the L+L EH with a short tail fitted has been documented before. It has been thought that this provided a good reference plate for the secondary E field operating in the longitudinal mode. On the other hand, its improved radiation with the tail might be simply due to it operating as an ordinary loaded vertical radiator which is just longer. Of course the VK5BR_X antenna has no tail as its feeder is fed balanced right to the antenna centre.

The signal strength received from the 40 metre X3 antenna has been compared with that received from my 40 metre end fed inverted V antenna. Reports from around Australia indicate a signal level around 1.5 to 2 S points below the inverted V. We might take that as around 10 dB below.

The 80 metre X3 antenna has been compared to the end fed Inverted V operated on 80 metres as a 5/8 wavelength long wire antenna resonated against ground. A station 2 km away recorded the X3 antenna as one S point below the wire antenna.

The 10 metre X3 antenna was been assembled so that, with the shorter wavelength, some tests could be carried out within the suburban backyard but outside of the near field region.

I have carried out a lot performance testing on Z Match Tuners, but not on 10 metres. Hence there was a question of how well they might work with the X3 system at 10 metres. My Single Z Match unit matched up OK and appeared to be working efficiently. Operation with a short length open wire line within the radio shack produced a little bit of current unbalance in the legs of the line. However the currents balanced up quite well with the antenna mounted outside and connected by a longer length of line. I was unable to get a satisfactory match using my Two Coil Compact Coil (Rononymous) Z Match Unit.

Earlier tests on the 20 metre X3 antenna within the near field area indicated maximum E field off the ends of the antenna. This was clearly a characteristic of the near field as by using the 10 metre X3 antenna with a field metre outside the near field zone, I was able to confirm that best radiation occurred when the antenna was mounted vertical and that it appeared vertically polarised.

I have not established any radiated field comparisons for the 10 metre antenna but Claudio Re (I1RFQ) carried out some field measurements on a 10 metre X3 antenna by comparing its field to that from a ground plane reference antenna. He derived figures of 10 dB down and an efficiency of the X3 as 10 %. In amateur radio terms this represents about 1.5 S points down and seems to agree with some test reports I have received at the lower frequencies of 1 to 2 S points down on a full size antenna.

Some General Notes

A considerable degree of loss can occur in the Z Match Tuner depending on the length of line and what actual impedance components are reflected back to the Z Match. So because of losses here, overall efficiency can be quite variable. It is also possible to get a wrong match where the SWR meter facing the transmitter indicates a match but the

tuner circuit is actually matched to an unbalanced form of load it has found. I find that it pays to check with a fluoro lamp for a balanced field around the two dipole plates on the antenna. If it is one sided, it is probably an erroneous match.

The X2/X3 antenna was made for experiments on a single amateur band. However using the Z Match to tune it in the shack, the X3 antenna can be made to operate over a wide range of frequencies such that it can be used on more than one harmonically related band. For example, the 20 metre antenna has been tuned up on 40 metres and has been quite effective in communication with other stations on that second lower frequency band.

Radiation Efficiency

The ultimate test for the antenna is its radiation efficiency or the ratio of power radiated to the power fed its input terminals. One way to evaluate this efficiency is to consider the ratio between the total series load resistance R_t and the series loss resistance R_L which was initially thought to be mainly due to the RF resistance of the series coils. To do this, the two secondary windings of the coils in series are resonated with the antenna capacitance by adjusting precise frequency until this occurs. A rough check to find this frequency can be made by inserting a Dip Meter close to the inside of one of the coils and adjusting the meter frequency for the dip. The actual resistance measurement is made by breaking the series link between the two coils and measuring impedance in between. Precise resonance frequency is indicated by zero reactance. To get the RF loss resistance component on its own, substitute the antenna dipole with a good low loss capacitor (perhaps air dielectric) of the same capacitance as the antenna to produce the resonance at the same frequency. The test is illustrated in figure 9.

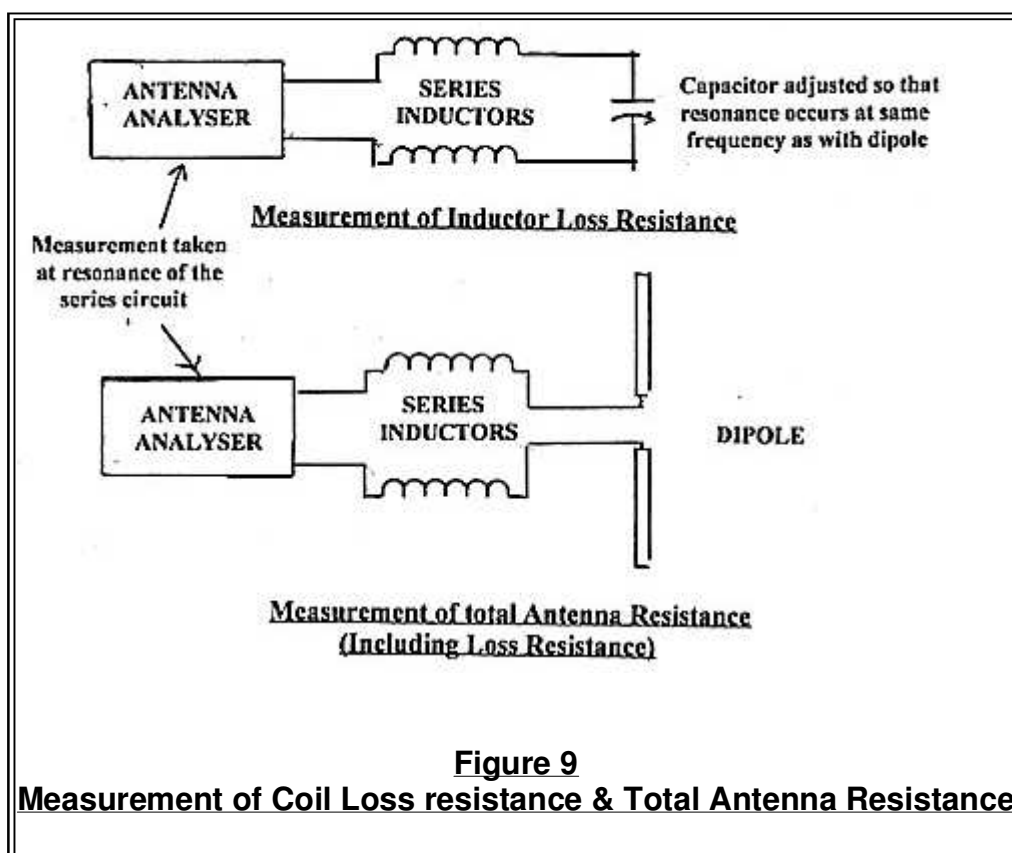

A well known formula for the approximate value of radiation resistance in a simple shortened dipole is as follows:

$$R_r = 320(\pi L_r / \lambda)^2$$

where L_r = Effective length in metres

and λ = wavelength in metres

$$L_r = 2L/\pi, \text{ where } L \text{ is actual length in metres}$$

$$\text{Hence } R_r = 320(L/\lambda)^2$$

Based on this formula to calculate radiation resistance, simple dipoles of similar length to the X2/X3 (2% to 3% of a wavelength) would have a radiation resistance of around 0.1 to 0.3 ohm. Coil loss resistance in various antenna models has been in the region of 4 to 8 ohms, so in measuring total resistance of the antenna, a resistance little different to that coil loss resistance would be seen.

However in making measurements using a floating antenna analyser, total resistance at least twice the coil loss resistance has been recorded. Some of this can be shown to result from induction into objects or earth which are too close to the antenna. But the remainder has been taken as radiation resistance very much higher than that of the calculated figure for the basic dipole and assumed to be due to the interacting E and H fields and proof of the crossed field operation.

One questionable aspect of this explanation is that the antenna still seemed to work when the coils were rotated by 90 degrees away from their maximum line of field. This was explained away by virtue of the fact that a field around an open coil spreads at all angles.

However it was suggested to me that the theory of interaction could be tested by substituting the open coils with two coils of equal inductance but wound on toroidal iron dust cores. This would confine their magnetic fields essentially to the toroidal core and limit most of the interacting magnetic field.

So I wound two coils (Figure 3), 6.5 μH (23 turns) on 50mm T200 iron dust cores and tried them on both of the 20 metre X3 antennas I had but used the X2 connection because I needed to take resistance measurement. The series loss resistance measured at resonance, with a fixed capacitor substituted for the antenna capacitance, proved to be 1 or 2 ohms less than the open coils.

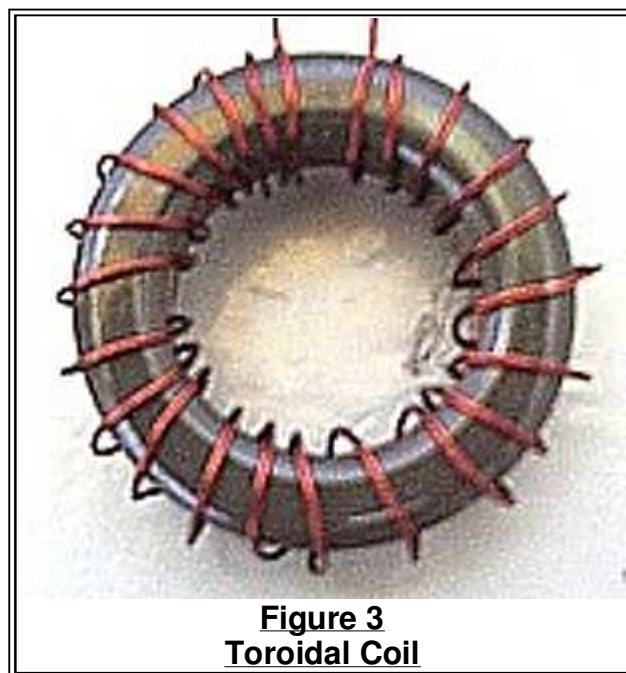

Assuming that all the magnetic field from the toroidal coils was confined, the resistance reading with antenna dipole connected should have been almost the same as the previous coil loss resistance reading.. Not so! In fact, the total resistance with the toroidal coils was considerably higher than with the open coils. This resistance on one antenna, resonating at 14.8 MHz, was as high as 24 ohms, nearly three times the loss resistance.

Further to this, when powered, the antenna seemed to be operating and radiating at least as well (if not better) when using the toroidal coils.

All this leads to assumption that my original theory for the X2/X3 antennas operating in a crossed field or field interacting mode was wrong. There had to be some other explanation why the apparent radiation resistance is raised well above that of around 0.1 or 0.3 ohms derived from common formula for the 2% to 3% wavelength dipole.

Dielectric Loss.

The antenna dipole capacitance is very low and somewhat less than 10 pf, for the higher frequency HF antennas, to a little more the 10 pf for the 80 metre antenna. (So we see reactances of over 1000 ohms at 14 MHz and 3000 ohms at 3.5 MHz). The total inductive reactance of the two coils in series is selected close to the capacitive reactance of the dipole capacitive reactance at a frequency within the band of operation

The previous test procedure has been to assume that losses in the antenna circuit were essentially due to losses in the series coils. However as discussed above, the high Q creates a very high impedance across the capacitance of the antenna. Quoting the example of a series resistance of 20 ohms and a $Q = 50$, the shunt resistance across the capacitance at resonance is $20 \times 50 \text{ squared} = 50,000$ ohms. Such resistance could, in part, be due to excessive dielectric loss resistance in the insulating plates separating the dipole elements.

It seemed to me strange that the series resistance measurement on the 10 metre antenna was so much lower than the 20 metre antenna. The only difference was that the insulating plates for the 10 metre antenna were made of plexiglass (which appears to be a form of polystyrene) whereas those for the 20 metre antenna were made of hardboard. So I re-made the separating plates for the 20 metre antenna in plexiglass (as shown in figure 2b) and this lowered the series resistance by

about 8 ohms to a value nearer to the loss resistance determined for the coils.

I then operated on the 40 and 80 metre antennas. In these, I cut the centres out of the hardboard separating plates so that a skeleton plate was left sufficient to fix the dipole elements apart and provide mounting for the coils. (Refer to the photographs). This lowered the series resistance of the 40 metre antenna by 6 ohms and the 80 metre antenna by 5 ohms.

The resistances of these two antennas were still considerably higher than the coil resistances, but at these lower frequencies, it appears that considerable coupling takes place to surrounding objects and particularly earth. In particular, the resistance of the 80 metre antenna rises considerably as its height above the ground is increased and increasing to values as high as 44 ohms.

Whilst I was on the job I thought I should check out other available insulating materials, so I also tested the 20 metre antenna with plates made from PVC sheet and the 10 metre antenna with plates made with polyethylene sheet. These gave similar results to the plexiglass. It was only my hardboard which clearly showed the high dielectric loss.

Summary

X2/X3 models of the antenna have been made for base frequencies on 10 metres, 20 metres, 40 metres and 80 metres. Tests on these antennas indicate signal radiated about 1.5 to 2 S points below a full sized resonant antenna.

The short antenna has application where there is limited space to erect a full sized resonant antenna. A limitation of the small antenna size is that its reactive components are large compared to its resistive component. Hence the Q is high and bandwidth is small, limiting across band coverage. By tuning from within the radio shack via the open wire lines, the tuning can be tracked across the band to overcome this problem.

Each of the antennas described have been made to operate on one amateur frequency band but it is possible to tune them up using the Z Match on a harmonically lower band with some reduction in performance to that of the base band.

The construction of these antennas was initially aimed at operation in a crossed field mode. Measurements of antenna series resistance above that of coil loss resistance seemed to indicate enhanced radiation from the crossed field. However it was eventually discovered that the rise in antenna resistance was essentially due to other factors. If there is any resistance increase due to crossing of the fields, it is too small for me to accurately measure and I no longer classify the X2/X3 as working in a crossed field mode.

The dipole length of the 20 metre X2/X3 is very similar to that of the 20 metre L+L EH antenna. It is interesting that when the EH antenna was trapped right at the antenna input terminal to stop longitudinal current flow, the two antennas produced similar strengths of field. If the radiation from X2/X3 antenna is not enhanced by its crossed field, then perhaps the EH antenna is not either. The EH antenna was 3 to 4 dB better with the trap at 1.5 metres down the feedline but this gives a longitudinal length (including the matching network) of 2.5 metres rather than the 0.5 metre of the dipole alone. (This could imply a radiation resistance as a normal dipole of 5 ohms rather than less than 1 ohm and this fact could well explain the improvement.).

I eventually discovered that, like the EH antenna, the X3 antenna works much better if connected in an unbalanced mode [Click for more information on how the X3 Antenna operates in that mode](#)

[Back to HomePage](#)