

Unwanted Coupling of Stray Signal or Noise

by Lloyd Butler VK5BR

(Originally published in Amateur Radio, June 1993)

The article discusses how circuit connections and module commons are arranged to minimise interference from stray signals or noise

Introduction

Most of us who have assembled electronic equipment have experienced unwanted coupling of noise into our circuits or instability because of coupling between circuit stages or modules. An elementary understanding of how this coupling occurs and how it can be reduced can save a few headaches. With this in mind we will discuss relevant topics such as induction into cable and lines, common mode currents and coupling due to common earth or power rail impedance.

Coupling into Cables or Transmission Lines

Signals can be coupled into cables or lines from both stray electric fields and stray magnetic fields. Most vulnerable are low-level audio lines such as those connected to microphones and antenna lines connected to radio receivers. Microphone lines are particularly prone to induction of audio frequency noise from power wiring and other stray fields. They can also pick up higher frequency fields which are generated by nearby radio transmitters. In this case, the RF signal is often rectified in the audio amplifiers to be detected as audio frequency interference, or the amplifiers are overloaded by the signal and saturate. If the microphone is connected to the transmitter generating the RF signal, the system can become unstable. This is often experienced in the amateur radio station as distorted audio or severe oscillation on the modulated signal.

Localised noise fields caused by noisy power lines and noisy electrical appliances are usually greatest in the vicinity of power wiring which conducts the noise signal. For the radio receiver, this source of noise induction can usually be reduced by ensuring that RF signal pick-up is confined to the antenna proper, with minimal pick-up in the feeder cable. Hopefully, the antenna proper will be distanced from the power wiring.

We now turn our attention to the line circuit impedance. Figure 1 shows an interfering circuit coupled via stray capacitance into our cable or line signal circuit. The source impedance and the load impedance of our signal circuit are both equal to a resistance value R . For a given signal power level, the signal voltage at the load is proportional to the square root of the value of R . On the other hand, assuming the reactance of the stray capacitance is large compared to R , the noise voltage across the load R is almost directly proportional to the value of R . Comparing these relationships, we can resolve that, for capacitively coupled noise (the electric component), the ratio of noise voltage to signal voltage is lowest when the circuit impedance is lowest.

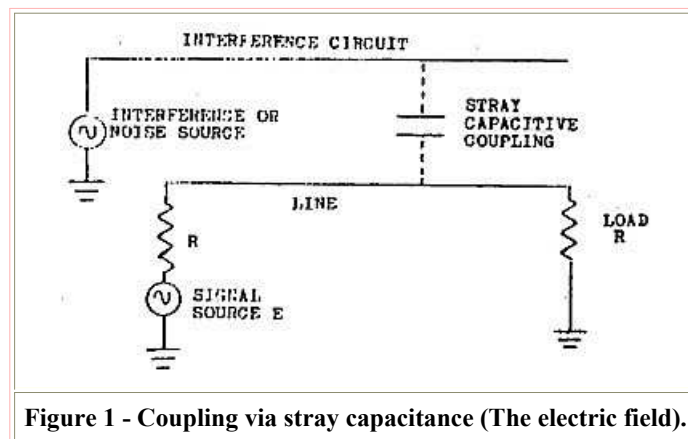

Figure 1 - Coupling via stray capacitance (The electric field).

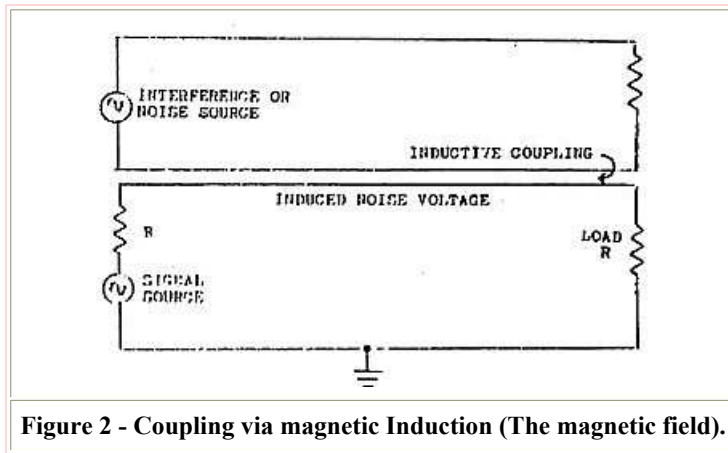

Figure 2 - Coupling via magnetic Induction (The magnetic field).

We now discuss coupling of the interference signal via the magnetic field. In Figure 2, one leg of our signal circuit is inductively coupled to our interference or noise source by its proximity to one leg of the noise source so that a noise voltage is induced in series with our signal circuit.

For a given signal power level, the signal current in the load resistance R is proportional to the square root of the reciprocal of R . If we assume a fixed noise voltage induced into the active leg of the signal circuit, the noise current in R is directly proportional to the reciprocal of R . The voltages across R are proportional to the currents through it and, comparing the preceding relationships, we can conclude that for inductively coupled noise (the magnetic field) the ratio of noise voltage to signal voltage is lowest when the circuit impedance is highest. This is opposite of that for the electric field and, hence, in a given line circuit, there can be an optimum value of circuit impedance which gives the best overall signal to noise ratio, considering both types of field.

Shieldings

Coupling from an electric noise field can be minimised by electrostatic shielding. For wiring, the active lead or leads are clad with a metallic braided sheath. It is normally necessary to run low-level lines, such as those from microphones, in this shielded wire. Figure 3A shows a shielded microphone line with the shield earthed at its two ends at different points in a building. The problem here is that noise voltage exists between the two earth points. If you want proof that such potentials exist, just connect an AC voltmeter between water taps in different rooms of a building, or between two earth stakes at different locations. Quite sizeable AC voltage can usually be detected, developed from stray earth currents. Referring again to Figure 3A, the potential between the two earth points causes noise current flow in the shield with voltage developed across the series resistance and inductive reactance of the shield. This noise voltage is in series with the microphone circuit and is added to the microphone signal voltage. The golden rule is to only connect one earth at the amplifier end of the shield, as shown in Figure 3B so that the noise current cannot flow from the earth system.

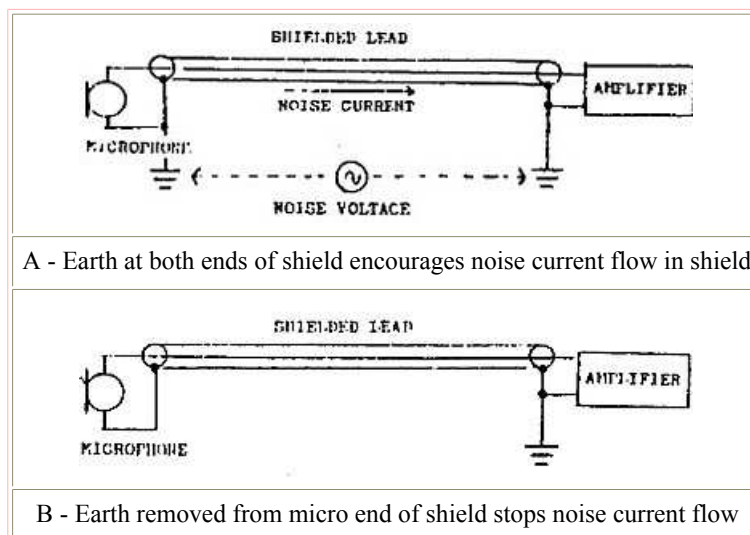
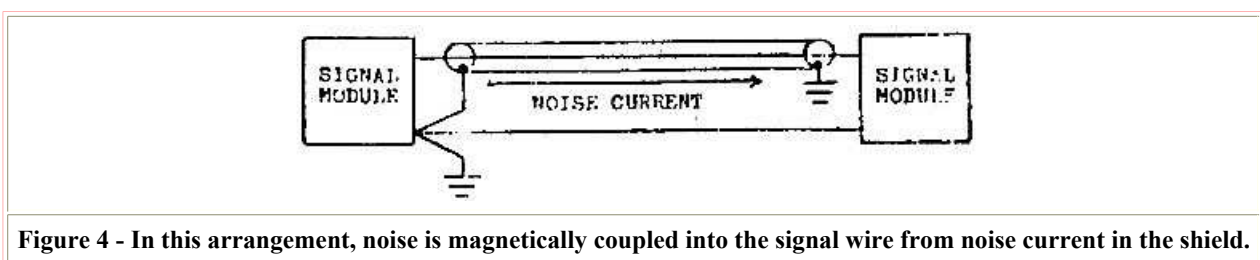

Figure 3 - Earthing of microphone cable shield

Another undesirable connection is shown in Figure 4 where two signal modules are connected by a shielded wire. The modules are both earthed at the one point, but one end of the shield is connected to a different earth location. In this case, the noise voltage developed along the shield is no longer in series with the signal circuit, but is coupled into the signal circuit by magnetic induction. To correct this problem, the right-hand shield connection should either be taken out or, instead, connected to the second module common. At radio frequencies, where coaxial lines connect matched circuits, the second option obviously has to be used.



The same principle of single and earthing applies to antenna feed lines. Where an antenna is mounted on a metal tower and fed with coaxial cable, the outer conductor of the cable is by necessity normally connected to the antenna structure. This, in turn, is fitted to the tower and also electrically connected. If the antenna structure can be electrically insulated from the tower, the outer shield of the coax cable feeder will be more effective as a noise shield. Unfortunately, most of our antenna hardware does not allow us to easily do this.

Balanced Lines

So far we have considered noise induced into unbalanced lines which have one active wire and an earth return line. Where signals must be transmitted some distance, or where coupling between adjacent line circuits must be reduced, balanced wire pairs are used. Circuits connected to the lines are balanced against ground, and the wire pairs are twisted or regularly transposed in some way so that any external electric or magnetic field induces equal currents into the two conductors. Figure 5 shows a balanced line coupled at each end to equipment via a transformer winding which is centre tapped. If the centre taps at both ends are earthed or connected to some other common bus, the induced interference currents (I_n) flow via the common connection. These are called longitudinal or common mode currents. While the signal current (I_s) induces a voltage in the secondary winding of the transformer, the induced interference currents in the two wire legs create equal and opposing magnetic fields in the transformer and induction into the transformer secondary is cancelled.

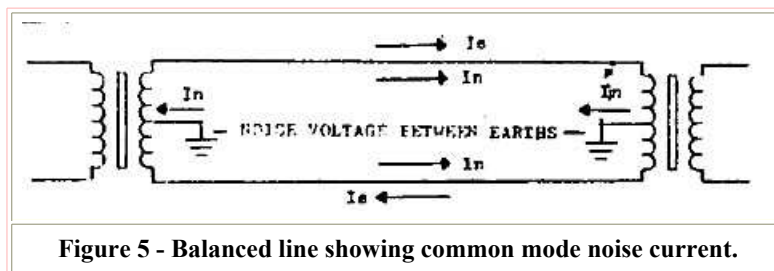

Of course, balanced circuits are not always well balanced so that the opposing fields do not completely balance, and some interference or noise signal is induced into the secondary. This can be reduced by leaving one or both centre taps floating so that a return path for the common mode circuit is blocked, preventing current flow. This also prevents noise current flow resulting from noise voltage existent between the two earths as discussed in previous paragraphs.

For many low-level circuits, such as microphone lines, the circuit is both balanced and shielded. In this case, the cable shield and the centre tap are both floated at the microphone with earthing only at the end facing the amplifier. The case of the microphone, which shields the microphone insert, is connected to the cable shield.

For the low-level microphone line, a low impedance is chosen to minimise noise induction from electric fields, but not so low that the line is more affected by magnetic fields. A modern broadcast station standard is a 200 ohm microphone source impedance operating into a 600 ohm load. (An earlier standard was 50 ohms operating into around 150 ohms load).

Sometimes we make use of the common mode or longitudinal path in our balanced lines to operate a control or switching circuit. In the days when open wire lines were used for trunkline telephone systems, telegraphs were operated over the common circuits. This type of circuit was called a cailho circuit. Two cailho circuits over two balanced lines were also often used to make a third balanced circuit for voice frequency operation, and this was called a phantom circuit. To go one further, the phantom circuit was centre tapped to form a cailho over which telegraph could be used. The arrangement is shown in Figure 6. Balanced circuits, such as these, which operate at audio power levels of around one milliwatt (0dBm) achieve crosstalk and noise levels satisfactory for speech communication.

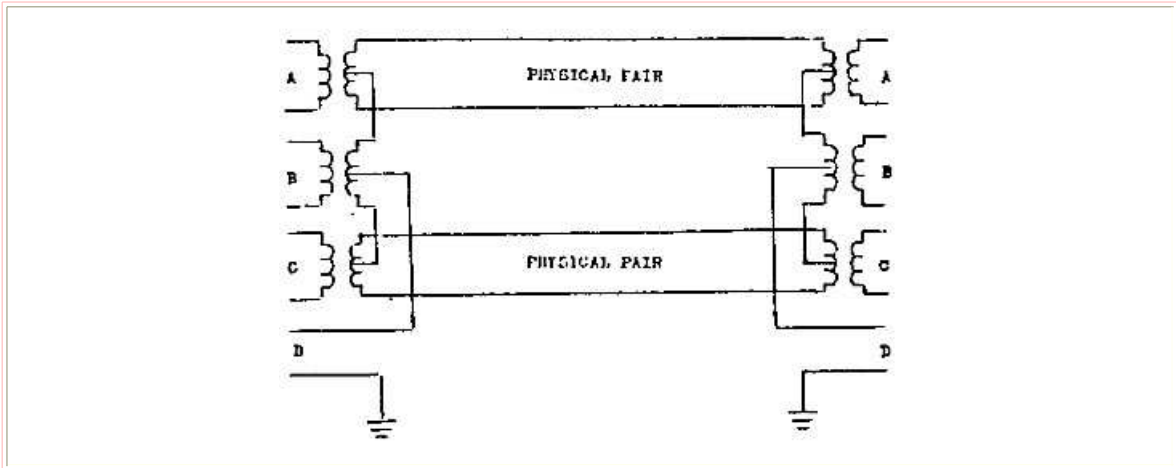

Figure 6 - Making use of common mode circuits to derive further circuits (Cailho and Phantom Circuits).

Of course, leakage to earth can occur on these balanced lines when there is a faulty insulator on an open wire pair, or when water gets into a cable carrying the line pairs. This causes an imbalance in the line, inviting induction from external noise fields of crosstalk from other adjacent open wire circuits or cable pairs. This is often what has happened when our telephone lines get noisy.

Balanced RF Circuits

Common mode currents in balanced circuits operating at radio frequencies can be effectively blocked by using a balanced choke of adequate inductance (refer Figure. 7). The choke, wound on a ferromagnetic core, is bifilar wound to produce high magnetic coupling between the two windings. The common mode currents (I_n) are in phase through the choke windings and are impeded by the choke's inductive reactance. On the other hand, the signal currents (I_s) through the two windings are in antiphase and the magnetic fields produced from these cancel so that they see zero inductance (at least in theory). Hence, the signal is allowed to pass while the common mode current is opposed.

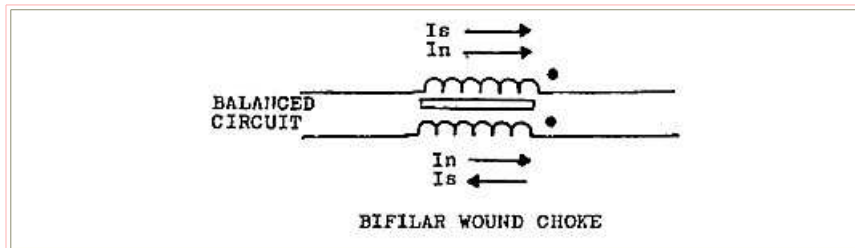

Figure 7 - Use of balanced choke to remove common mode signal component

Power cords and coaxial RF lines are often wound around a piece of ferrite to reduce radio interference into the appliance to which they are connected. In effect, this is a form of balanced choke to impede the common mode or longitudinal RF currents induced in all wires or legs of the cable. In the case of the power cord, we have a trifilar wound choke with common inductance in series with active, neutral and earth leads. The success of the choke is dependent on whether the inductive reactance, at the frequency concerned, is sufficient to attenuate the common mode current to a satisfactory level.

Common mode currents can also be blocked by the insertion of a transformer with separate primary and secondary windings, but coupling still occurs via capacitance across the windings. At audio frequency, the capacitive coupling is virtually eliminated by an electrostatic shield fitted between primary and secondary. At radio frequencies, the elimination of capacitive coupling is difficult if a high coefficient of coupling is to be maintained. Modern RF transformers are multifilar wound on ferrite cores to obtain a high coupling coefficient, making it difficult to incorporate a shield.

RF Filters

Sometimes we fit RF filters in such equipment as a nearby TV receiver to reject interference from our radiated HF signal. High pass filters such as those shown in Figure 8 have a cutoff frequency set to block the HF spectrum while still permitting passage of the VHF-UHF spectrum. Connected in series with the TV receiver antenna line, they are supposed to stop HF pick-up in the antenna or antenna feed line from being fed to the TV receiver. The filter is often ineffective because it has poor immunity to signal pick-up in the common or longitudinal mode. To include common mode rejection, either a balanced choke or a transformer with isolated primary and secondary must be added. To add a matter of interest, the combined filter with common mode rejection also works in reverse to reject TV line timebase noise from being radiated from the TV antenna line and interfering with the HF receiver.

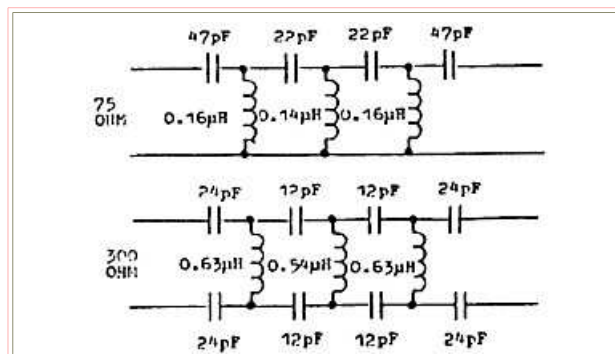

Figure 8 Typical high pass TV transmission line filters

It must be emphasised that, to provide common mode rejection, the usual type of TV balun transformer (300/75 ohm) does not do the job. This is normally wound as an auto transformer which does not offer common mode rejection.

Coupling Due to Common impedance

Noise in a circuit module is often picked up from another noisy module because their earth connection (or active power supply connections) are returned to the power supply bus via a common lead as shown in Figure 9A. The common lead has resistance and reactance, the latter of which increases with frequency. The noisy circuit supply current develops a noisy voltage across the other circuit via the common connection. To eliminate this type of problem, the earth lead (or active supply lead) of each module is returned separately to a single point on the supply bus as shown in Figure 9B.

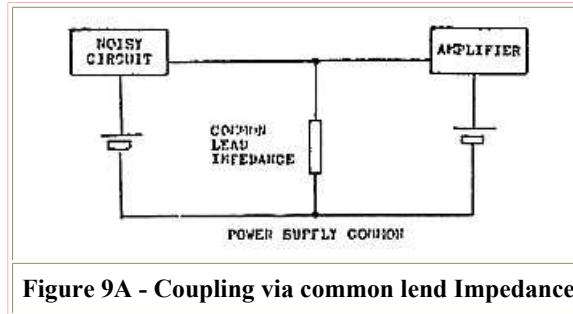

Figure 9A - Coupling via common lead Impedance

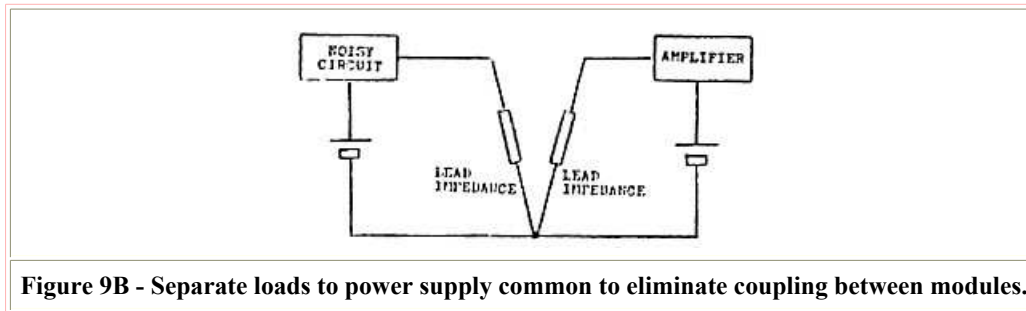

Figure 9B - Separate loads to power supply common to eliminate coupling between modules.

Figure 10A shows a number of circuit modules with earths or power feed lines commoned together by looping one to the other. Where there is a chance of signal interaction between these circuits, the interaction from common lead impedance can be minimised by commoning at one point as shown in Figure 10B.

At RF frequencies, the idea of singlepoint earthing still applies, but as frequency is increased into the VHFUHF region, the earthing system can be more defined by the need of short leads in the RF layout.

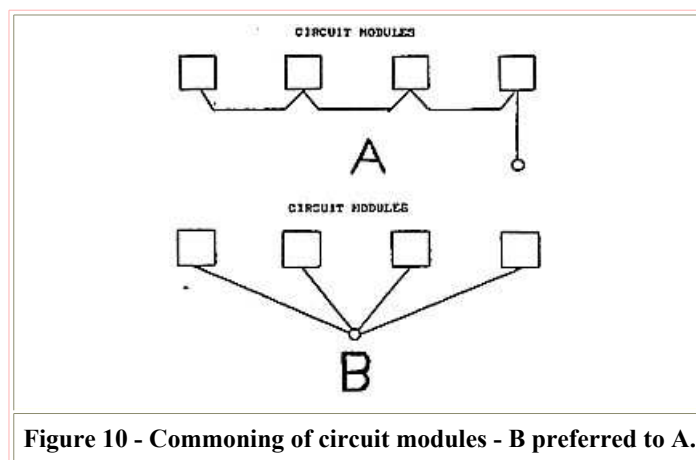
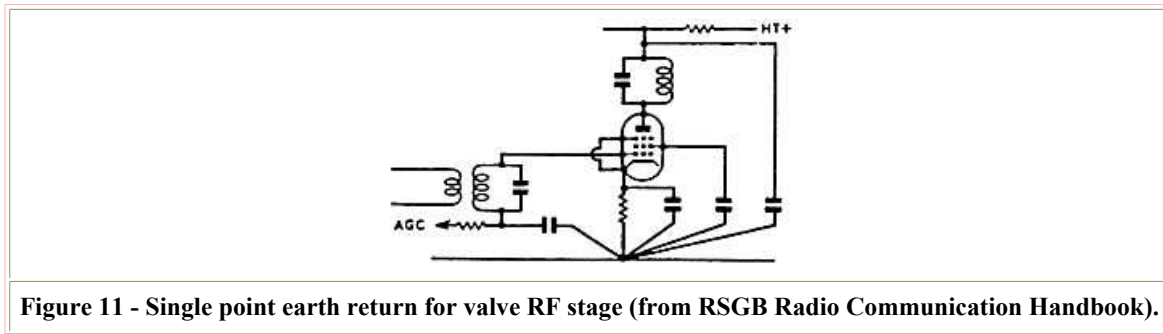

Figure 10 - Commoning of circuit modules - B preferred to A.

Stage Earth Returns

Past practice in electron tube or valve amplifiers has been to use a metal chassis as a common earth plane to join earths of individual valve stages. To prevent regeneration or degeneration in an individual stage via a common impedance, good practice for high frequencies was to connect all earth returns for the stage to a common earth point at the valve socket.

The common point, and only that point, was bonded to the chassis. The system is shown in Figure 11.



The same principle can be applied to solid state circuits. All earth returns for a single transistor stage, or a single integrated circuit package, are returned to the one point which is bonded to a ground plane. In using printed circuit board, the ground plane is provided by the copper sided board. There are various ways of doing this, but one way is to use one copper side of the board as the ground plane while the other is used for the printed wiring links and the component pads.

Connection of Power to Common Bus

Let us now consider a typical circuit board on which there are a number of amplifier stages starting at a low signal level and ending at a high signal level. The low-level stage takes only a few milliamps from the power rails, whereas the high-level stage runs a supply load current of hundreds of milliamps or greater. The power rails run along the board in consecutive order of the stage levels, with connections made first to the low-level stage and last to the high level stage.

First we connect the power supply leads to the rails at the low-level stage end as shown in Figure 12A. In this case, the high current to the output stage, complete with a proportional value of ripple from the power supply, must pass through the section of the rail marked X. This can develop noise voltage across the rail impedance at X and into the low-level stage.

Another effect is that some of the output stage AC signal current can appear on the rail so that output signal component is developed across the rail impedance shown as Y. This can cause instability because of feedback to the input stage. In an audio frequency amplifier this often shows up as low frequency "motor boating" because at very low frequencies, the power rail bypass capacitors become ineffective.

Problems of excessive power supply ripple noise or amplifier instability, as discussed, are often completely solved by re-positioning the power supply connections to the high-level stage section of the power rails as shown in Figure 12B. By doing this, the power rails connected to the low-level stages no longer carry the high current (with its high noise or signal component) to the high-level output stage. Of course, the wise thing is to connect it up the Figure 12B way in the first place.

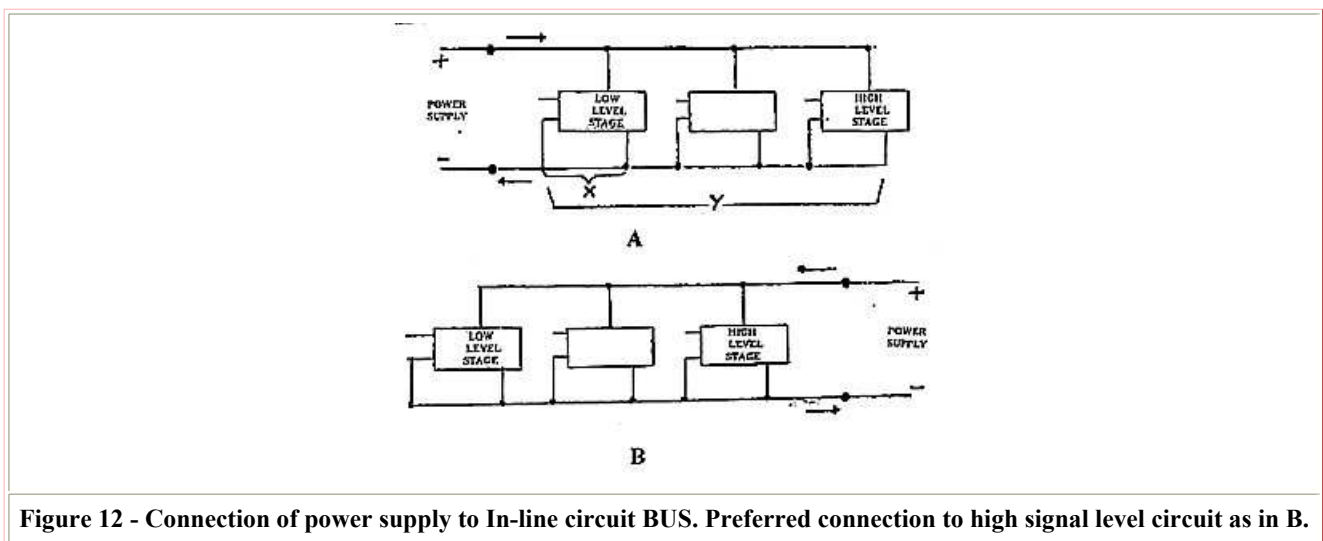

Induction Into Components

Low-level stages usually require shielding to prevent coupling from electric or magnetic fields created by higher level

stages or from stray external sources. Some types of inductors have open magnetic fields and can be the cause of stray fields as well as being prone to picking up other fields. Inductors and transformers wound on toroidal cores have confined fields and hence are less prone to interference than those wound on straight ferrite rods. The miniature RF chokes, so useful to make up passive filters, have open fields and must be spaced from each other to prevent interaction. Pot cores have a winding enclosed by ferrite so that their fields are confined to the ferrite material.

To shield components from electric fields, metal screens are used. Low conductivity material, such as copper, also provides a magnetic shield at high frequencies. Eddy currents induced into the material set up an opposing field which tends to cancel the initiating field outside the confines of the screen. Ferro-magnetic materials can also be used to shield from magnetic fields. An example of this is the screen around a cathode ray tube.

So far we have described stray coupling in terms of induced noise and causing instability. In the case of passive filters, there are a few other effects, if too much coupling occurs between the inductors. This is often experienced when using those miniature RF chokes. The coupling can cause change of inductance and loss of Q, resulting in shifting of the cut-off point of the filter and degrading its slope. Loss of Q and stray input to output coupling can also degrade the out-of band attenuation. Of course, the effects of the stray coupling are not always obvious unless the response of the filter is measured and compared to the theoretical model.

Summary

We have discussed various ways in which unwanted signal or noise components can be coupled into our circuits, and we have suggested how this coupling can be reduced. We have dealt with lines and cables in the presence of electric and magnetic interference fields and how the degree of interference from these fields is affected by line or circuit impedance. Shielding has been covered with particular reference to care in earthing. The discussion has led into the use of balanced lines to reduce induction of interference, and the effects of longitudinal currents in these lines. Further discussion has centred around unwanted coupling into circuit modules and components and unwanted coupling between modules and components. The need to avoid certain common supply lines to different modules and the advantage of singlepoint earthing have also been emphasised.

Getting rid of noise pick-up or stopping interaction between circuits is often treated on a hit-and-miss basis. However, a little thought concerning how the coupling might be occurring can save a lot of trouble. Furthermore, if some of the basic precautions are taken in the first place, the unwanted coupling might be avoided.

This article is fairly basic, but it has been prepared to emphasise several important procedures in connecting up circuits. Hopefully it will provide a little help to the experimenter or home constructor in avoiding those problem bugs.

References

1. Rich, Alan - Understanding Interference-type Noise - Analog Dialogue 16-3 1982.
2. RSGB Radio Communications Handbook, Fourth Edition - Section 1, Unbalanced and Balanced Circuits - Section 4, Construction.

[Back to HomePage](#)